

Cobra Plus Grade 10 Clevis Jaw Shackle – 1094

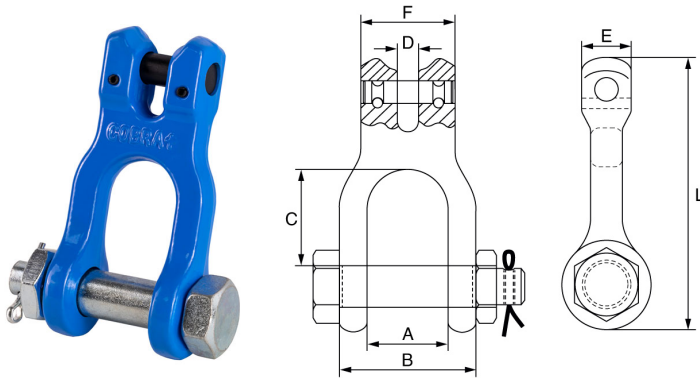

- Grade 10 alloy steel, quenched and tempered.
- Blue painted finish.
- Meets W.L.L. perf. req. of BS EN 1677-1 +25% of loads.
- Temp. Range -20°C up to +200°C.
- M.B.L. equals 4 x W.L.L.
- Marked with Cobra+, material grade, size, product ID mark and traceability code.
- Certs available **2.1** **DoC**

Product Code	Chain Dia	A	B	C	D	E	F	L
	mm	mm	mm	mm	mm	mm	mm	mm
G100CJS8	8	31	51	36.3	9	20	36	103.5
G100CJS10	10	34	62	48	12.5	25	46.5	130.7
G100CJS13	13	49	83	64	15	31	59	160
G100CJS16	16	58	95	69.5	19	40	70	190.5

Technical Data

Chain Dia mm	W.L.L. t	M.P.F. t	M.B.F. t	Weight kgs
8	2.5	6.25	10	0.48
10	4	10	16	0.89
13	6.7	16.75	26.8	1.51
16	10	25	40	2.62