

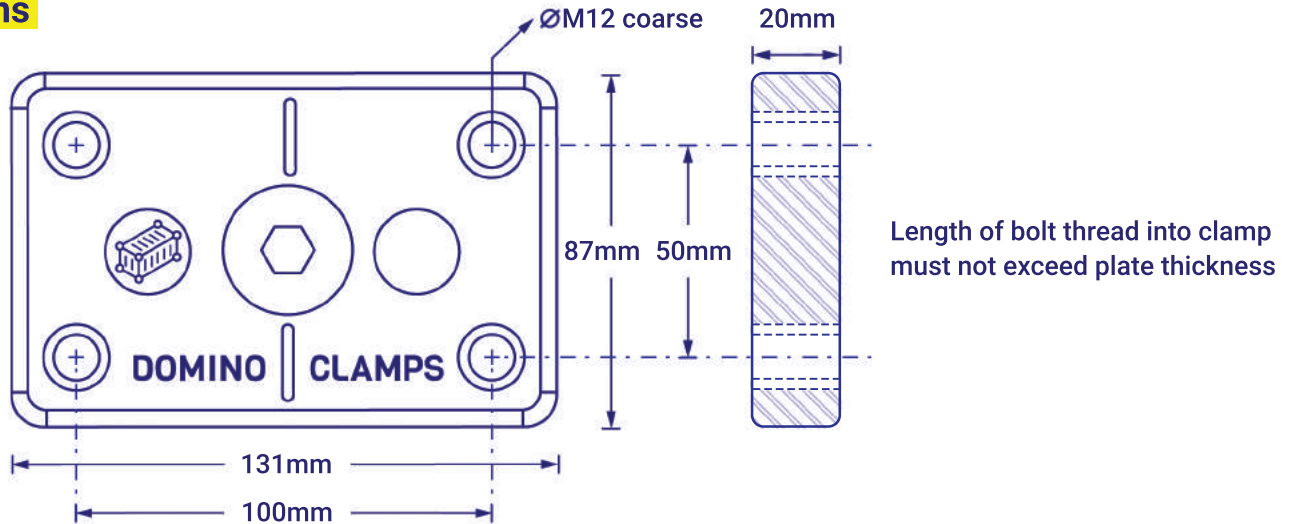

The smartest way to attach almost anything to shipping containers

Domino Clamp Technical Sheet

Dimensions



Recommended working loads



Side Holes (stadium shape)

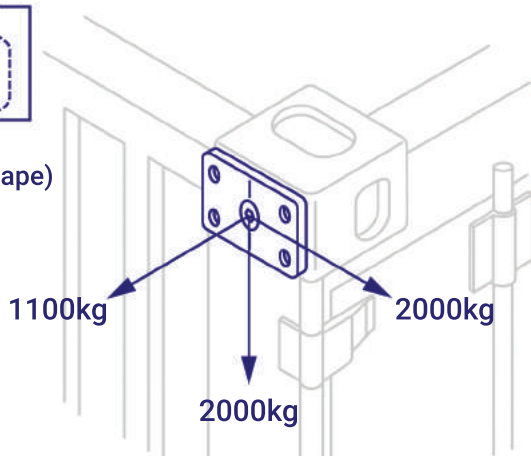

Top end holes (Shield Shape)

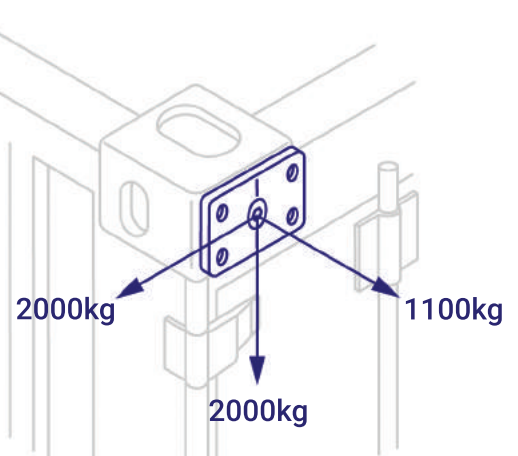

Notes

Factor of safety between ultimate & working loads: 5:1
 For use only with ISO 1161 standard corner castings.
 Clamp is to be used in front and side of corner casting as shown only.
 Use only supplied Grade 10.8 custom bolt for tightening.
 Use only metric M12 coarse thread (1.75) screws in the Domino.
Recommended torque tightening bolt: 40Nm
 In long term installations, check tightening bolt at regular intervals.
 If the clamp is subject to constant vibration, we advise the use of a thread locking liquid on the centre bolt..

Material Specification:

Forged Steel Grade EN3B (070M20)
 European Standard EN10083-1

Coatings:

Base layer: Electroplated zinc
 Finish: Xylan 1010

Total Weight:

2.4kg (85oz)



RECOMMENDED TORQUE 40Nm



USE ONLY WITH ISO1161 CASTINGS



NOT FOR LIFTING



NOT FOR USE IN TOP OR BOTTOM HOLES