

Viper Horizontal Plate Lifting Clamp VHPC – PDB Type

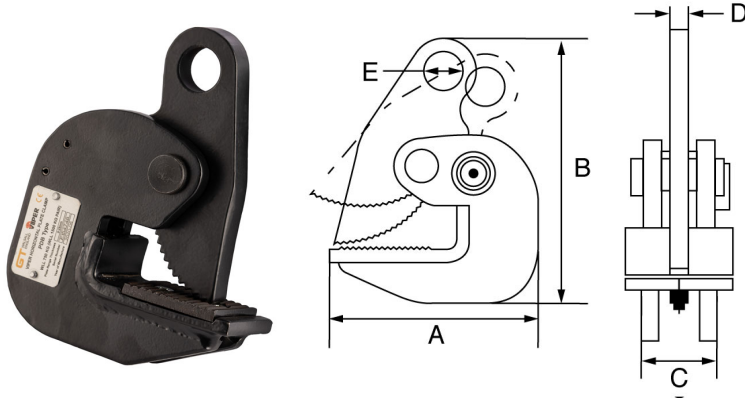

Certs available **2.1**
DoC

- Specially hardened steel is used in both the serrated jaws.
- Matt black finish.
- Meets the W.L.L. performance requirements of BS EN 13155.
- Minimum breaking load is 4 times the W.L.L.
- The steel plate lifted should be under the HRC 37 (HB 345).
- Lifting under 20% of the rated capacity loading is strictly forbidden.
- The GT Viper plate clamp is designed to lift one plate at a time.
- Marked in accordance with BS EN 13155.

Product Code	Capacity Per Pair kgs	Jaw Opening mm	A mm	B mm	C mm	D mm	E mm	Weight kgs
VHPC1.5	1,500	0 - 25	125	175	38	14	22	2.5
VHPC2	2,000	0 - 30	155	205	38	16	25	3.5
VHPC3	3,000	0 - 30	158	205	42	16	25	4
VHPC4	4,000	0 - 40	180	252	46	18	30	5

Product Code	Capacity Per Pair	Jaw Opening	A	B	C	D	E	Weight
	kgs	mm	mm	mm	mm	mm	mm	kgs
VHPC5	5,000	0 - 45	185	252	50	18	30	6
VHPC6	6,000	0 - 45	185	252	50	18	30	6
VHPC8	8,000	0 - 50	180	260	52	18	30	6.5
VHPC10	10,000	0 - 55	185	260	56	20	30	7.5
VHPC12	12,000	0 - 65	210	308	62	22	37	10.5
VHPC16	16,000	0 - 100	282	400	65	25	55	22
VHPC20	20,000	0 - 125	325	500	75	28	55	33