

HYDRAULIC ROTATIONAL TOE JACK

HM50/100/250

LES
LIFTING EQUIPMENT STORE™

Finish	Painted
Standards	USA ASME/ANSI B30.1.198
Safety Factor	
Markings / Certification	
Notes	360° Rotation

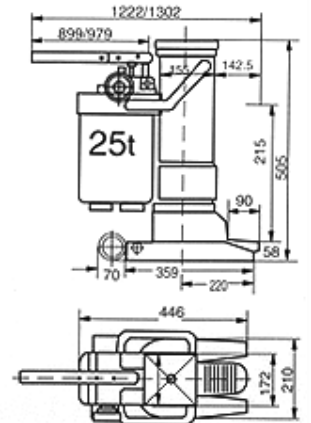
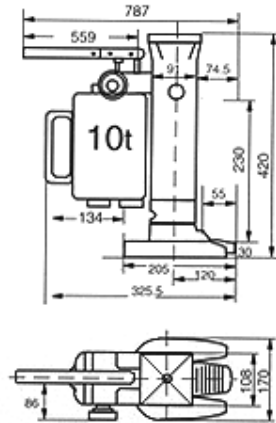
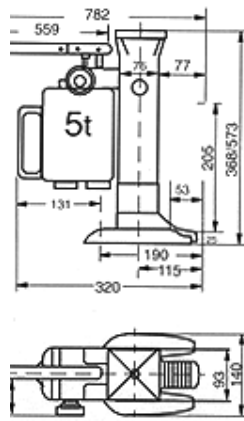

Model	Capacity	Lifting Range of Foot	Lifting Range of Head	Max. Lever Force	Weight
HM50	5,000kg	25-230mm	368-573mm	38kg	25kg
HM100	10,000kg	30-260mm	420-650mm	40kg	35kg
HM250	25,000kg	58-273mm	505-720mm	40kg	102kg