

HA Swivel Hoist Ring (Metric)

HA Swivel Hoist Ring (Metric)

The HA swivel hoist ring (metric) is a bolt-on load attachment product designed for use with loads that incorporate tapped holes. It can rotate 360° around the bolt axis, as well as pivot 180°, allowing the hoist ring to orientate to the appropriate angle of lift, mitigating the risk of damage. The HA swivel hoist ring (metric) is suitable for both top and side mounting, and maintains its full working load limit even when pulled at 90°.

Standards: designed and manufactured in accordance with EN1677-1 and ASME B30.26.

Product sizes: available in sizes M8 to M64 and with working load limits from 0.5 tonnes to 22.5 tonnes.

Product markings: forged bail marked with manufacturer name "Hackett" and batch number for product material traceability. Body marked with recommended torque rating and working load limits (based on 4 : 1 and 5 : 1 safety factors). Bolt marked with metric size, material grade, "HA" branding, and batch number for bolt material traceability.

Temperature: operational temperature range of - 40°C to + 200°C without reduction in working load limit.

Material: alloy steel.

Testing: load rated parts are subject to 100% magnaflux crack detection following heat treatment. HA swivel hoist rings are proof tested to 2.5 times working load limit, and fatigue rated to 1.5 times working load limit.

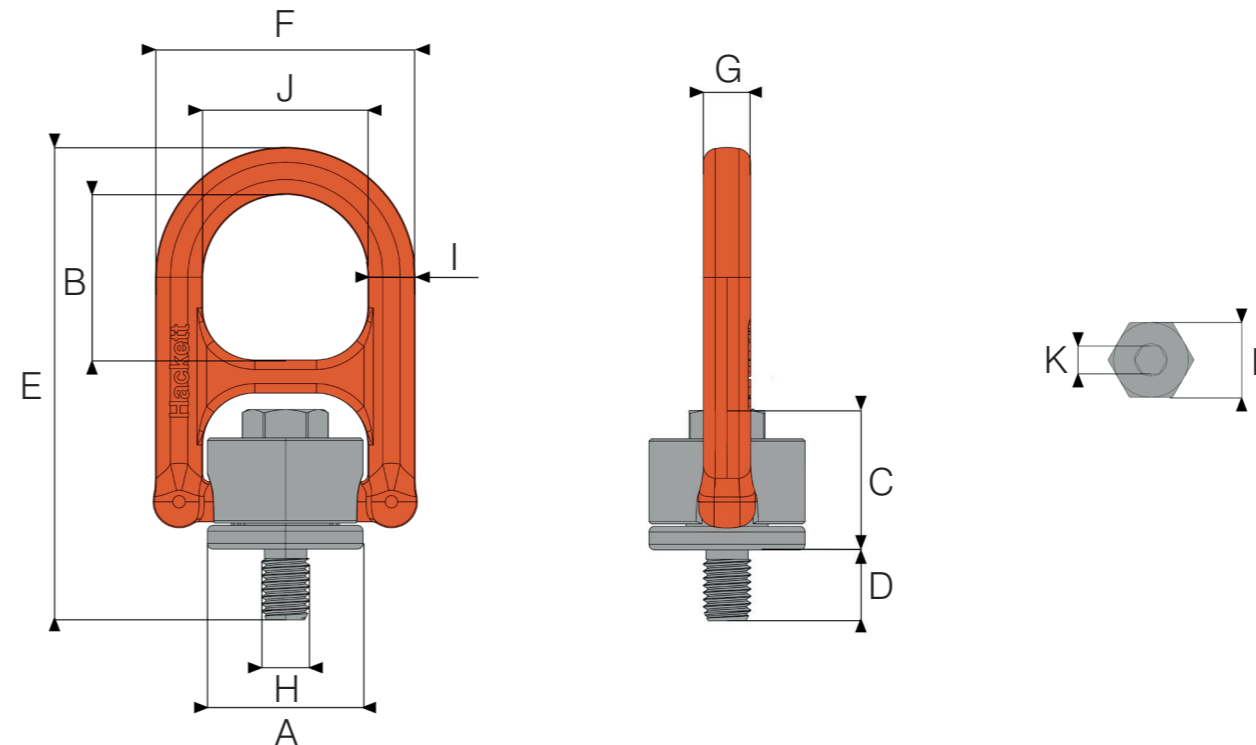

Specifications

Part Code	WLL t	Thread M	A mm	B mm	C mm	D mm	E mm	F mm	G mm	H mm	I mm	J mm	K mm	L mm	Torque Nm	Mass kg
8-H20-M8G	0.5	M8	33	35	30	12	97	55	10	8	10	35	6	16	30	0.3
8-H20-M10G	0.7	M10	33	35	30	15	100	55	10	10	10	35	6	16	60	0.3
8-H20-M12G	1.0	M12	33	35	30	20	105	55	10	12	10	35	6	16	100	0.3
8-H20-M16G	2.0	M16	50	55	47	24	155	82	13	16	14	54	10	24	150	1.0
8-H20-M20G	3.0	M20	65	66	58.5	30	193	105	16	20	18	69	12	30	250	2.0
8-H20-M24G	5.0	M24	65	66	58.5	36	199	105	16	24	18	69	14	36	400	2.1
8-H20-M30G	7.8	M30	87	80	82.5	48	266	145	25	30	27	91	17	46	500	5.7
8-H20-M36G	12.5	M36	110	100	94	56	311	186	33	36	36	88	19	70	800	11.9
8-H20-M42G	15.6	M42	110	100	98	63	318	186	33	42	36	88	19	70	800	12.0
8-H20-M48G	20.0	M48	110	100	98	72	327	186	33	48	36	88	19	70	800	12.3
8-H20-M56G	22.0	M56	123	110	110	84	363	199	35	56	36	97	19	80	800	16.4
8-H20-M64G	22.5	M64	123	110	110	95	374	199	35	64	36	97	19	80	800	17.1

HA Swivel Hoist Ring (Metric)

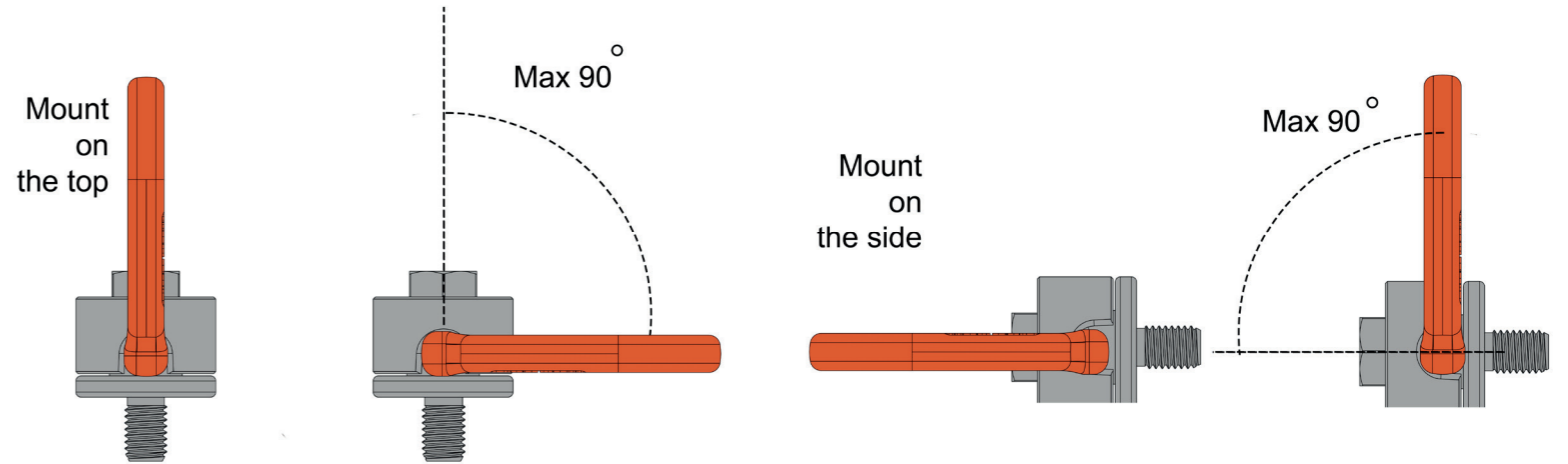

Number of legs	Load Direction										
	0°	0°	90°	90°	0-45°	45-60°	unsym	0-45°	45-60°	unsym	
Part Code	Thread										
	WLL (in tonnes) by Lifting Application										
8-H20-M8G	M8	0.5	1.0	0.5	1.0	0.7	0.5	0.5	1.1	0.8	0.5
8-H20-M10G	M10	0.7	1.4	0.7	1.4	1.0	0.7	0.7	1.5	1.1	0.7
8-H20-M12G	M12	1.0	2.0	1.0	2.0	1.4	1.0	1.0	2.1	1.5	1.0
8-H20-M16G	M16	2.0	4.0	2.0	4.0	2.8	2.0	2.0	4.2	3.0	2.0
8-H20-M20G	M20	3.0	6.0	3.0	6.0	4.2	3.0	3.0	6.3	4.5	3.0
8-H20-M24G	M24	5.0	10.0	5.0	10.0	7.0	5.0	5.0	10.5	7.5	5.0
8-H20-M30G	M30	7.8	15.6	7.8	15.6	10.9	7.8	7.8	16.4	11.7	7.8
8-H20-M36G	M36	12.5	25.0	12.5	25.0	17.5	12.5	12.5	26.3	18.8	12.5
8-H20-M42G	M42	15.6	31.2	15.6	31.2	21.8	15.6	15.6	32.8	23.4	15.6
8-H20-M48G	M48	20.0	40.0	20.0	40.0	28.0	20.0	20.0	42.0	30.0	20.0
8-H20-M56G	M56	22.0	44.0	22.0	44.0	30.8	22.0	22.0	46.2	33.0	22.0
8-H20-M64G	M64	22.5	45.0	22.5	45.0	31.5	22.5	22.5	47.3	33.8	22.5