

Onyx Grade 80 Clevis Shortening Clutch with Pin – OXCSCP

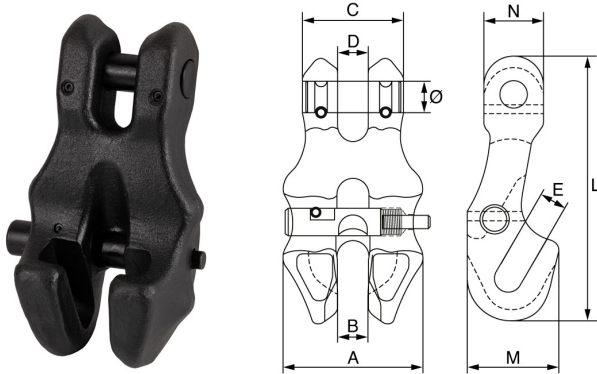

ONYX

- Grade 80 alloy steel, quenched and tempered.
- Matte black painted.
- Meets the W.L.L. perf. req. of BS EN 1677-1.
- -20°C up to +200°C.
- M.B.L. equals 4 x W.L.L.
- Marked with ONYX, material grade, size, product ID mark and traceability code.
- Certs available **2.1** **DoC**

| Product Code | Chain Dia | A | B | C | D | M | N | L | Ø |
|--------------|-----------|----|------|------|------|------|----|-----|----|
| | mm | mm | mm | mm | mm | mm | mm | mm | mm |
| OXCSCP8 | 7/8 | 50 | 9.5 | 33 | 9.5 | 33 | 23 | 92 | 9 |
| OXCSCP10 | 10 | 60 | 11.7 | 43.5 | 11.7 | 42.2 | 26 | 115 | 13 |
| OXCSCP13 | 13 | 79 | 15 | 55 | 15 | 54 | 34 | 149 | 16 |

Technical Data

| Product Code | Chain Dia mm | W.L.L. t | M.P.L. t | M.B.L. t | Weight kgs | PDF |
|--------------|-----------------|-------------|-------------|-------------|---------------|---|
| OXCSCP8 | 7/8 | 2 | 4 | 8 | 0.37 |  |
| OXCSCP10 | 10 | 3.15 | 6.3 | 12.6 | 0.97 |  |
| OXCSCP13 | 13 | 5.3 | 10.6 | 21.2 | 2.01 |  |