

Screw jacks

MERKUR standard screw jacks

Features and processing

High flexibility: covering a load range from 0.25 t to 50 t, the MERKUR ranges is versatile in use. The ranges with cubic housing allows access on all sides and thus easy alignment of the screw jacks during installation. The MERKUR ranges is optimally used where high loads have to be positioned at medium duty cycles and low dynamics.

9 different sizes

Lifting capacities from 2.5 to 500 kN

Input speeds up to 1500 min⁻¹

- All-round configuration permits easier alignment
- Conforms to European manufacturers' standards for cubic shaped worm gear screw jacks
- Self-locking trapezoidal screw
- Grease-lubricated configuration
- Worm gear pairs in two ratio steps (normal „N“ and slow „L“)

 **Possible usage according to directive 2014/34/EU (ATEX)**

The MERKUR ranges impresses with its performance and application: the screw jacks allow and enable, for example, the (storm-)safe opening and closing of wind turbine maintenance hatches.

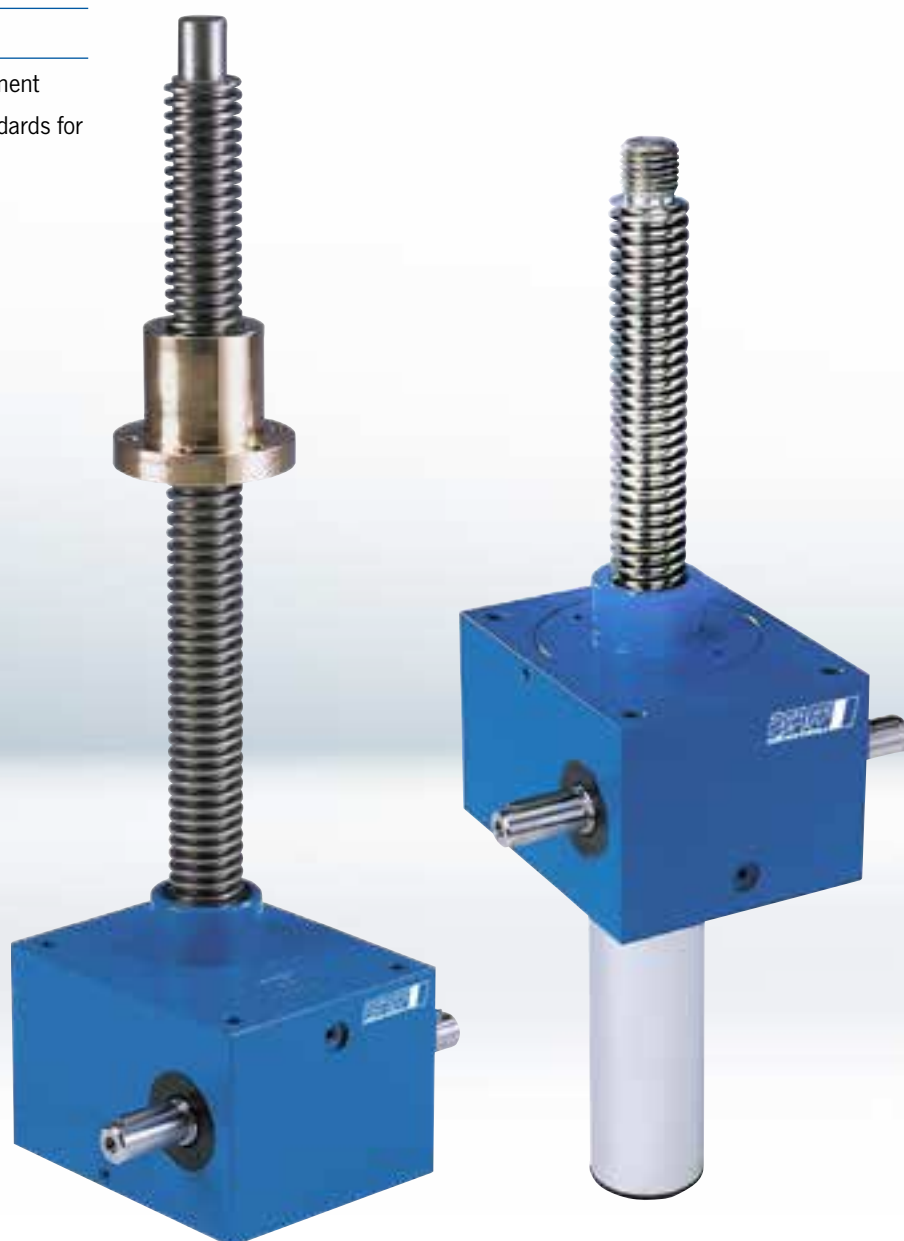

A



B



C

D

MERKUR range

Selection table

Selection table screw jack MERKUR									
Size	M 0	M 1	M 2	M 3	M 4	M 5	M 6	M 7	M 8 ⁴⁾
Max. lifting capacity dynamic/static [kN]	2,5	5	10	25	50	150	250	350	500
Max. tensile load dynamic/static [kN]	2,5	5	10	25	50	150	250	350	500
Screw Tr ¹⁾	14x4	18x4	20x4	30x6	40x7	60x9	80x10	100x10	120x14
Ratio N	4:1	4:1	4:1	6:1	7:1	9:1	10:1	10:1	14:1
Lift per revolution for ratio N [mm/per rev.]	1	1	1	1	1	1	1	1	1
Ratio L	16:1	16:1	16:1	24:1	28:1	36:1	40:1	40:1	56:1
Lift per revolution for ratio L [mm/per rev.]	0,25	0,25	0,25	0,25	0,25	0,25	0,25	0,25	0,25
Max. drive capacity ²⁾ at T = 20 °C Duty cycle (ED) 20 %/h [kW]	0,12	0,2	0,3	0,5	0,9	2,6	3,7	on request	
Max. drive capacity ²⁾ at T = 20 °C Duty cycle (ED) 10 %/h [kW]	0,25	0,42	0,6	1,1	1,9	3,7	4,4	on request	
Screw efficiency rating [%]	49	42,5	40	40	36,5	32,5	29	24	28
Overall efficiency for ratio N [%]	34	30	28	27	25	19	19	15	15
Overall efficiency for ratio L [%]	24	23	21	19	18	14	14	11	11
Torque, capacity, turning-speed at 20 % ED/h and 20 °C	see performance tables page 50–51								
Screw torque at max. lifting power [Nm]	3,2	7,5	16	60	153	437	1390	2312	4100
Max. permitted drive-shaft torque [Nm]	1,5	3,4	7,1	18	38	93	240	340	570
Mass moment of inertia J ³⁾ Ratio N type 1 [kg cm ²]	0,07	0,122	0,16	0,78	1,917	3,412	16,04	49,12	96,27
Mass moment of inertia J ³⁾ Ratio N type 2 [kg cm ²]	0,069	0,126	0,165	0,794	1,952	3,741	17,58	52,45	103,39
Mass moment of inertia J ³⁾ Ratio L type 1 [kg cm ²]	0,045	0,088	0,115	0,558	1,371	2,628	12,35	37,05	72,62
Mass moment of inertia J ³⁾ Ratio L type 2 [kg cm ²]	0,05	0,091	0,119	0,552	1,381	2,647	12,44	37,37	73,15
Max. permitted screw length for compression load [mm]	see buckling diagrams page 152–153								
Housing material	LM25-TF			EN-GJL-250			EN-GJS-400-15		
Weight without stroke length and protection tube [kg]	0,6	1,2	2,1	6	17	32	57	85	160
Screw weight per 100 mm stroke [kg]	0,1	0,35	0,45	0,7	1,2	2	4,2	6,6	10,3
Amount of lubricant in worm gear [kg]	0,03	0,08	0,14	0,24	0,8	1,1	2	2,7	3,2

Dimension plans type 1: page 52–55, type 2: page 55–58

1) Also applies to Ku screw (see page 157)

2) Max. permitted values for type 1 and Tr screw. Higher values are possible when using type 2 or Ku screw.

3) Referring to 100 mm screw length

4) alternative SHE 50.1

Possible usage according to directive 2014/34/EU (ATEX)

A



B



C

D

MERKUR range

Performance tables (screw jacks with Tr screw)

MERKUR range (Cubic standard screw jacks)

Rotary speed, power requirement and permitted lifting speed for ratio N and L with single-start, **lifting (type 1) trapezoidal screw**. All performance data is expressed in terms of dynamic lifting capacity.

With duty ratio of < 10 %/h or configuration with rotating screw (type 2), the maximum permitted drive capacities can be increased. In this case, please consult our screw jack specialists.

Performance table MEKRUR 0 screw Tr 14x4

Speed n	Lifting speed		F = 2,5 kN				F = 2 kN				F = 1,5 kN				F = 1 kN				F = 0,75 kN				F = 0,5 kN				F = 0,25 kN					
	N	L	N	kW	N	kW	N	kW	N	kW	N	kW	N	kW	N	kW	N	kW	N	kW	N	kW	N	kW	N	kW	N	kW	N	kW		
[1/min]	[m/min]		Nm	kW	Nm	kW	Nm	kW	Nm	kW	Nm	kW	Nm	kW	Nm	kW	Nm	kW	Nm	kW	Nm	kW	Nm	kW	Nm	kW	Nm	kW	Nm	kW		
1500	1,5	0,375	1,2	0,18	0,4	0,1	0,9	0,15	0,3	0,1	0,7	0,1	0,2	0,1	0,5	0,1	0,2	0,1	0,4	0,1	0,1	0,1	0,2	0,1	0,1	0,1	0,1	0,1	0,1	0,1	0	0,1
1000	1	0,25	1,2	0,12	0,4	0,1	0,9	0,1	0,3	0,1	0,7	0,1	0,2	0,1	0,5	0,1	0,2	0,1	0,4	0,1	0,1	0,1	0,2	0,1	0,1	0,1	0,1	0,1	0,1	0,1	0	0,1
750	0,75	0,188	1,2	0,1	0,4	0,1	0,9	0,1	0,3	0,1	0,7	0,1	0,2	0,1	0,5	0,1	0,2	0,1	0,4	0,1	0,1	0,1	0,2	0,1	0,1	0,1	0,1	0,1	0,1	0,1	0	0,1
600	0,6	0,15	1,2	0,1	0,4	0,1	0,9	0,1	0,3	0,1	0,7	0,1	0,2	0,1	0,5	0,1	0,2	0,1	0,4	0,1	0,1	0,1	0,2	0,1	0,1	0,1	0,1	0,1	0,1	0,1	0	0,1
500	0,5	0,125	1,2	0,1	0,4	0,1	0,9	0,1	0,3	0,1	0,7	0,1	0,2	0,1	0,5	0,1	0,2	0,1	0,4	0,1	0,1	0,1	0,2	0,1	0,1	0,1	0,1	0,1	0,1	0,1	0	0,1
300	0,3	0,075	1,2	0,1	0,4	0,1	0,9	0,1	0,3	0,1	0,7	0,1	0,2	0,1	0,5	0,1	0,2	0,1	0,4	0,1	0,1	0,1	0,2	0,1	0,1	0,1	0,1	0,1	0,1	0	0,1	
100	0,1	0,025	1,2	0,1	0,4	0,1	0,9	0,1	0,3	0,1	0,7	0,1	0,2	0,1	0,5	0,1	0,2	0,1	0,4	0,1	0,1	0,1	0,2	0,1	0,1	0,1	0,1	0,1	0,1	0	0,1	
50	0,05	0,013	1,2	0,1	0,4	0,1	0,9	0,1	0,3	0,1	0,7	0,1	0,2	0,1	0,5	0,1	0,2	0,1	0,4	0,1	0,1	0,1	0,2	0,1	0,1	0,1	0,1	0,1	0,1	0	0,1	

Performance table MEKRUR 1 screw Tr 18x4

Speed n	Lifting speed		F = 5 kN				F = 4 kN				F = 3 kN				F = 2,5 kN				F = 2 kN				F = 1,5 kN				F = 1 kN			
	N	L	N	kW	N	kW	N	kW	N	kW	N	kW	N	kW	N	kW	N	kW	N	kW	N	kW	N	kW	N	kW	N	kW	N	kW
[1/min]	[m/min]		Nm	kW	Nm	kW	Nm	kW	Nm	kW	Nm	kW	Nm	kW	Nm	kW	Nm	kW	Nm	kW	Nm	kW	Nm	kW	Nm	kW	Nm	kW	Nm	kW
1500	1,5	0,375	2,7	0,42	0,9	0,1	2,1	0,33	0,7	0,1	1,6	0,25	0,5	0,1	1,3	0,21	0,4	0,1	1,1	0,2	0,3	0,1	0,8	0,1	0,3	0,1	0,5	0,1	0,2	0,1
1000	1	0,25	2,7	0,28	0,9	0,1	2,1	0,22	0,7	0,1	1,6	0,17	0,5	0,1	1,3	0,14	0,4	0,1	1,1	0,1	0,3	0,1	0,8	0,1	0,3	0,1	0,5	0,1	0,2	0,1
750	0,75	0,188	2,7	0,21	0,9	0,1	2,1	0,17	0,7	0,1	1,6	0,13	0,5	0,1	1,3	0,1	0,4	0,1	1,1	0,1	0,3	0,1	0,8	0,1	0,3	0,1	0,5	0,1	0,2	0,1
600	0,6	0,15	2,7	0,17	0,9	0,1	2,1	0,13	0,7	0,1	1,6	0,1	0,5	0,1	1,3	0,1	0,4	0,1	1,1	0,1	0,3	0,1	0,8	0,1	0,3	0,1	0,5	0,1	0,2	0,1
500	0,5	0,125	2,7	0,14	0,9	0,1	2,1	0,1	0,7	0,1	1,6	0,1	0,5	0,1	1,3	0,1	0,4	0,1	1,1	0,1	0,3	0,1	0,8	0,1	0,3	0,1	0,5	0,1	0,2	0,1
300	0,3	0,075	2,7	0,1	0,9	0,1	2,1	0,1	0,7	0,1	1,6	0,1	0,5	0,1	1,3	0,1	0,4	0,1	1,1	0,1	0,3	0,1	0,8	0,1	0,3	0,1	0,5	0,1	0,2	0,1
100	0,1	0,025	2,7	0,1	0,9	0,1	2,1	0,1	0,7	0,1	1,6	0,1	0,5	0,1	1,3	0,1	0,4	0,1	1,1	0,1	0,3	0,1	0,8	0,1	0,3	0,1	0,5	0,1	0,2	0,1
50	0,05	0,013	2,7	0,1	0,9	0,1	2,1	0,1	0,7	0,1	1,6	0,1	0,5	0,1	1,3	0,1	0,4	0,1	1,1	0,1	0,3	0,1	0,8	0,1	0,3	0,1	0,5	0,1	0,2	0,1

Performance table MEKRUR 2 screw Tr 20x4

Speed n	Lifting speed		F = 10 kN				F = 8 kN				F = 6 kN				F = 4 kN				F = 3 kN				F = 2 kN				F = 1 kN			
	N	L	N	kW	N	kW	N	kW	N	kW	N	kW	N	kW	N	kW	N	kW	N	kW	N	kW	N	kW	N	kW	N	kW	N	kW
[1/min]	[m/min]		Nm	kW	Nm	kW	Nm	kW	Nm	kW	Nm	kW	Nm	kW	Nm	kW	Nm	kW	Nm	kW	Nm	kW	Nm	kW	Nm	kW	Nm	kW	Nm	kW
1500	1,5	0,375	5,7	0,89	1,9	0,3	4,5	0,71	1,5	0,24	3,4	0,54	1,1	0,18	2,3	0,36	0,8	0,1	1,7	0,27	0,6	0,1	1,1	0,2	0,4	0,1	0,6	0,1	0,2	0,1
1000	1	0,25	5,7	0,6	1,9	0,2	4,5	0,48	1,5	0,16	3,4	0,36	1,1	0,12	2,3	0,24	0,8	0,1	1,7	0,18	0,6	0,1	1,1	0,1	0,4	0,1	0,6	0,1	0,2	0,1
750	0,75	0,188	5,7	0,45	1,9	0,15	4,5	0,36	1,5	0,12	3,4	0,27	1,1	0,1	2,3	0,18	0,8	0,1	1,7	0,13	0,6	0,1	1,1	0,1	0,4	0,1	0,6	0,1	0,2	0,1
600	0,6	0,15	5,7	0,36	1,9	0,12	4,5	0,29	1,5	0,1	3,4	0,21	1,1	0,1	2,3	0,14	0,8	0,1	1,7	0,1	0,6	0,1	1,1	0,1	0,4	0,1	0,6	0,1	0,2	0,1
500	0,5	0,125	5,7	0,3	1,9	0,1	4,5	0,24	1,5	0,1	3,4	0,18	1,1	0,1	2,3	0,12	0,8	0,1	1,7	0,1	0,6	0,1	1,1	0,1	0,4	0,1	0,6	0,1	0,2	0,1
300	0,3	0,075	5,7	0,18	1,9	0,1	4,5	0,14	1,5	0,1	3,4	0,11	1,1	0,1	2,3	0,1	0,8	0,1	1,7	0,1	0,6	0,1	1,1	0,1	0,4	0,1	0,6	0,1	0,2	0,1
100	0,1	0,025	5,7	0,1	1,9	0,1	4,5	0,1	1,5	0,1	3,4	0,1	1,1	0,1	2,3	0,1	0,8	0,1	1,7	0,1	0,6	0,1	1,1	0,1	0,4	0,1	0,6	0,1	0,2	0,1
50	0,05	0,013	5,7	0,1	1,9	0,1	4,5	0,1	1,5	0,1	3,4	0,1	1,1	0,1	2,3	0,1	0,8	0,1	1,7	0,1	0,6	0,1	1,1	0,1	0,4	0,1	0,6	0,1	0,2	0,1

Max. duty ratio at 20 °C ambient temperature: 20 %/h 10 %/h static only (dynamic not permitted)

MERKUR range

Performance tables (screw jacks with Tr screw)

Performance table MEKRUR 3 screw Tr 30x6

Speed n	Lifting speed		F = 25 kN				F = 20 kN				F = 15 kN				F = 10 kN				F = 5 kN				F = 2,5 kN				F = 1 kN			
	N	L	N	L	N	L	N	L	N	L	N	L	N	L	N	L	N	L	N	L	N	L	N	L	N	L	N	L		
[1/min]	[m/min]		Nm	kW	Nm	kW	Nm	kW	Nm	kW	Nm	kW	Nm	kW	Nm	kW	Nm	kW	Nm	kW	Nm	kW	Nm	kW	Nm	kW	Nm	kW	Nm	kW
1500	1,5	0,375	14,7	2,31	5,2	0,82	11,8	1,85	4,2	0,66	8,8	1,39	3,1	0,49	5,9	0,93	2,1	0,33	2,9	0,46	1	0,2	1,5	0,2	0,5	0,1	0,6	0,1	0,2	0,1
1000	1	0,25	14,7	1,54	5,2	0,55	11,8	1,23	4,2	0,44	8,8	0,93	3,1	0,33	5,9	0,62	2,1	0,22	2,9	0,31	1	0,1	1,5	0,2	0,5	0,1	0,6	0,1	0,2	0,1
750	0,75	0,188	14,7	1,16	5,2	0,41	11,8	0,93	4,2	0,33	8,8	0,69	3,1	0,25	5,9	0,46	2,1	0,16	2,9	0,23	1	0,1	1,5	0,1	0,5	0,1	0,6	0,1	0,2	0,1
600	0,6	0,15	14,7	0,93	5,2	0,33	11,8	0,74	4,2	0,26	8,8	0,56	3,1	0,2	5,9	0,37	2,1	0,13	2,9	0,19	1	0,1	1,5	0,1	0,5	0,1	0,6	0,1	0,2	0,1
500	0,5	0,125	14,7	0,77	5,2	0,27	11,8	0,62	4,2	0,22	8,8	0,46	3,1	0,16	5,9	0,31	2,1	0,11	2,9	0,15	1	0,1	1,5	0,1	0,5	0,1	0,6	0,1	0,2	0,1
300	0,3	0,075	14,7	0,46	5,2	0,16	11,8	0,37	4,2	0,13	8,8	0,28	3,1	0,1	5,9	0,19	2,1	0,1	2,9	0,1	1	0,1	1,5	0,1	0,5	0,1	0,6	0,1	0,2	0,1
100	0,1	0,025	14,7	0,15	5,2	0,1	11,8	0,12	4,2	0,1	8,8	0,1	3,1	0,1	5,9	0,1	2,1	0,1	2,9	0,1	1	0,1	1,5	0,1	0,5	0,1	0,6	0,1	0,2	0,1
50	0,05	0,013	14,7	0,1	5,2	0,1	11,8	0,1	4,2	0,1	8,8	0,1	3,1	0,1	5,9	0,1	2,1	0,1	2,9	0,1	1	0,1	1,5	0,1	0,5	0,1	0,6	0,1	0,2	0,1

Performance table MEKRUR 4 screw Tr 40x7

Speed n	Lifting speed		F = 50 kN				F = 40 kN				F = 30 kN				F = 20 kN				F = 10 kN				F = 5 kN				F = 2,5 kN			
	N	L	N	L	N	L	N	L	N	L	N	L	N	L	N	L	N	L	N	L	N	L	N	L	N	L	N	L		
[1/min]	[m/min]		Nm	kW	Nm	kW	Nm	kW	Nm	kW	Nm	kW	Nm	kW	Nm	kW	Nm	kW	Nm	kW	Nm	kW	Nm	kW	Nm	kW	Nm	kW	Nm	kW
1500	1,5	0,375	31,8	5	11,1	1,7	25,5	4	8,8	1,4	19,1	3	6,6	1	12,7	2	4,4	0,7	6,4	1	2,2	0,3	3,2	0,5	1,1	0,2	1,6	0,3	0,6	0,1
1000	1	0,25	31,8	3,3	11,1	1,2	25,5	2,7	8,8	0,9	19,1	2	6,6	0,7	12,7	1,3	4,4	0,5	6,4	0,7	2,2	0,2	3,2	0,3	1,1	0,1	1,6	0,2	0,6	0,1
750	0,75	0,188	31,8	2,5	11,1	0,9	25,5	2	8,8	0,7	19,1	1,5	6,6	0,5	12,7	1	4,4	0,35	6,4	0,5	2,2	0,2	3,2	0,3	1,1	0,1	1,6	0,1	0,6	0,1
600	0,6	0,15	31,8	2	11,1	0,7	25,5	1,6	8,8	0,6	19,1	1,2	6,6	0,4	12,7	0,8	4,4	0,3	6,4	0,4	2,2	0,1	3,2	0,2	1,1	0,1	1,6	0,1	0,6	0,1
500	0,5	0,125	31,8	1,7	11,1	0,6	25,5	1,3	8,8	0,5	19,1	1	6,6	0,3	12,7	0,7	4,4	0,2	6,4	0,3	2,2	0,1	3,2	0,2	1,1	0,1	1,6	0,1	0,6	0,1
300	0,3	0,075	31,8	1	11,1	0,3	25,5	0,8	8,8	0,3	19,1	0,6	6,6	0,2	12,7	0,4	4,4	0,1	6,4	0,2	2,2	0,1	3,2	0,1	1,1	0,1	1,6	0,1	0,6	0,1
100	0,1	0,025	31,8	0,3	11,1	0,1	25,5	0,3	8,8	0,1	19,1	0,2	6,6	0,1	12,7	0,1	4,4	0,1	6,4	0,1	2,2	0,1	3,2	0,1	1,1	0,1	1,6	0,1	0,6	0,1
50	0,05	0,013	31,8	0,2	11,1	0,1	25,5	0,1	8,8	0,1	19,1	0,1	6,6	0,1	12,7	0,1	4,4	0,1	6,4	0,1	2,2	0,1	3,2	0,1	1,1	0,1	1,6	0,1	0,6	0,1

Performance table MEKRUR 5 screw Tr 60x9

Speed n	Lifting speed		F = 150 kN				F = 100 kN				F = 80 kN				F = 60 kN				F = 40 kN				F = 20 kN				F = 10 kN			
	N	L	N	L	N	L	N	L	N	L	N	L	N	L	N	L	N	L	N	L	N	L	N	L	N	L	N	L		
[1/min]	[m/min]		Nm	kW	Nm	kW	Nm	kW	Nm	kW	Nm	kW	Nm	kW	Nm	kW	Nm	kW	Nm	kW	Nm	kW	Nm	kW	Nm	kW	Nm	kW	Nm	kW
1500	1,5	0,375	125,7	19,7	42,6	6,7	83,8	13,2	28,4	4,5	67	10,5	22,7	3,6	50,3	7,9	17,1	2,7	33,5	5,3	11,4	1,8	16,8	2,6	5,7	0,9	8,4	1,3	2,8	0,4
1000	1	0,25	125,7	13,2	42,6	4,5	83,8	8,8	28,4	3	67	7	22,7	2,4	50,3	5,3	17,1	1,8	33,5	3,5	11,4	1,2	16,8	1,8	5,7	0,6	8,4	0,9	2,8	0,3
750	0,75	0,188	125,7	9,9	42,6	3,3	83,8	6,6	28,4	2,2	67	5,3	22,7	1,8	50,3	3,9	17,1	1,3	33,5	2,6	11,4	0,9	16,8	1,3	5,7	0,4	8,4	0,7	2,8	0,2
600	0,6	0,15	125,7	7,9	42,6	2,7	83,8	5,3	28,4	1,8	67	4,2	22,7	1,4	50,3	3,2	17,1	1,1	33,5	2,1	11,4	0,7	16,8	1,1	5,7	0,4	8,4	0,5	2,8	0,2
500	0,5	0,125	125,7	6,6	42,6	2,2	83,8	4,4	28,4	1,5	67	3,5	22,7	1,2	50,3	2,6	17,1	0,9	33,5	1,8	11,4	0,6	16,8	0,9	5,7	0,3	8,4	0,4	2,8	0,1
300	0,3	0,075	125,7	3,9	42,6	1,3	83,8	2,6	28,4	0,9	67	2,1	22,7	0,7	50,3	1,6	17,1	0,5	33,5	1,1	11,4	0,4	16,8	0,5	5,7	0,2	8,4	0,3	2,8	0,1
100	0,1	0,025	125,7	1,3	42,6	0,4	83,8	0,9	28,4	0,3	67	0,7	22,7	0,2	50,3	0,5	17,1	0,2	33,5	0,4	11,4	0,1	16,8	0,2	5,7	0,1	8,4	0,1	2,8	0,1
50	0,05	0,013	125,7	0,7	42,6	0,2	83,8	0,4	28,4	0,1	67	0,4	22,7	0,1	50,3	0,3	17,1	0,1	33,5	0,2	11,4	0,1	16,8	0,1	5,7	0,1	8,4	0,1	2,8	0,1

Performance table MEKRUR 6 screw Tr 80x10

Speed n	Lifting speed		F = 250 kN				F = 200 kN				F = 150 kN				F = 100 kN				F = 80 kN				F = 60 kN				F = 40 kN			
	N	L	N	L	N	L	N	L	N	L	N	L	N	L	N	L	N	L	N	L	N	L	N	L	N	L	N	L		
[1/min]	[m/min]		Nm	kW	Nm	kW	Nm	kW	Nm	kW	Nm	kW	Nm	kW	Nm	kW	Nm	kW	Nm	kW	Nm	kW	Nm	kW	Nm	kW	Nm	kW	Nm	kW
1500	1,5	0,375	209,4	32,9	71,1	11,2	167,5	26,3	56,8	8,9	125,7	19,7	42,6	6,7	83,8	13,2	28,4	4,5	67	10,5	22,7	3,6	50,3	7,9	17,1	2,7	33,5	5,3	11,4	1,8
1000	1	0,25	209,4	21,9	71,1	7,4	167,5	17,5	56,8	6	125,7	13,2	42,6	4,5	83,8	8,8	28,4	3	67	7	22,7	2,4	50,3	5,3	17,1	1,8	33,5	3,5	11,4	1,2
750	0,75	0,188	209,4	16,4	71,1	5,6	167,5	13,2	56,8	4,5	125,7	9,9	42,6	3,3	83,8	6,6	28,4	2,2	67	5,3	22,7	1,8	50,3	3,9	17,1	1,3	33,5	2,6	11,4	0,9
600	0,6	0,15	209,4	13,2	71,1	4,5	167,5	10,5	56,8	3,6	125,7	7,9	42,6	2,7	83,8	5,3	28,4	1,8	67	4,2	22,7	1,4	50,3	3,2	17,1	1,1	33,5	2,1	11,4	0,7
500	0,5	0,125	209,4	11	71,1	3,7	167,5	8,8	56,8	3	125,7	6,6	42,6	2,2	83,8	4,4	28,4	1,5	67	3,5	22,7	1,2	50,3	2,6	17,1	0,9	33,5	1,8	11,4	0,6
300	0,3	0,075	209,4	6,6	71,1	2,2	167,5	5,3	56,8	1,8	125,7	3,9	42,6	1,3	83,8	2,6	28,4	0,9	67	2,1	22,7	0,7	50,3	1,6	17,1	0,5	33,5	1,1	11,4	0,4
100	0,1	0,025	209,4	2,2	71,1	0,7	167,5	1,8	56,8	0,6	125,7	1,3	42,6	0,4	83,8	0,9	28,4	0,3	67	0,7	22,7	0,2	50,3	0,5	17,1	0,2	33,5	0,4	11,4	0,1
50	0,05	0,013	209,4	1,1	71,1	0,4	167,5	0,9	56,8	0,3	125,7	0,7	42,6	0,2	83,8	0,4	28,4	0,1	67	0,4	22,7	0,1	50,3	0,3	17,1	0,1	33,5	0,2	11,4	0,1

A



MERKUR range

Technical drawings: Type 1

Technical drawings MERKUR: Type 1, Standard

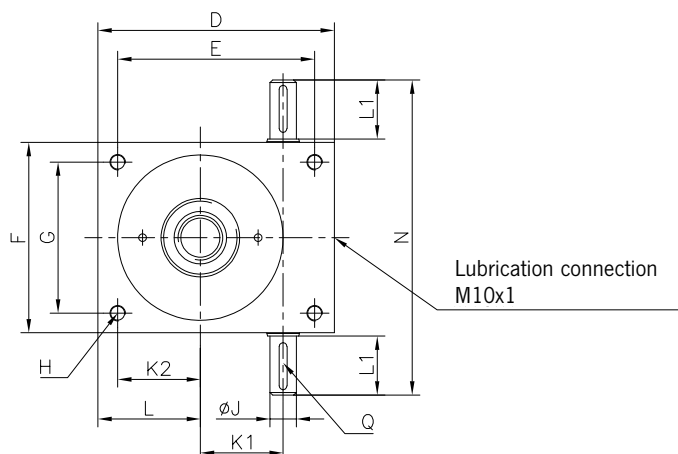
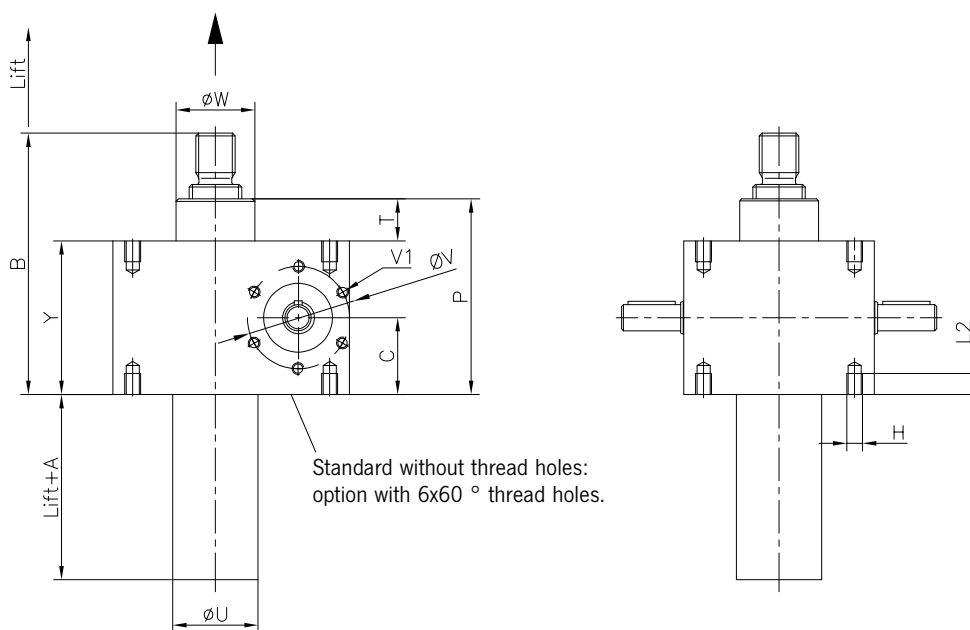
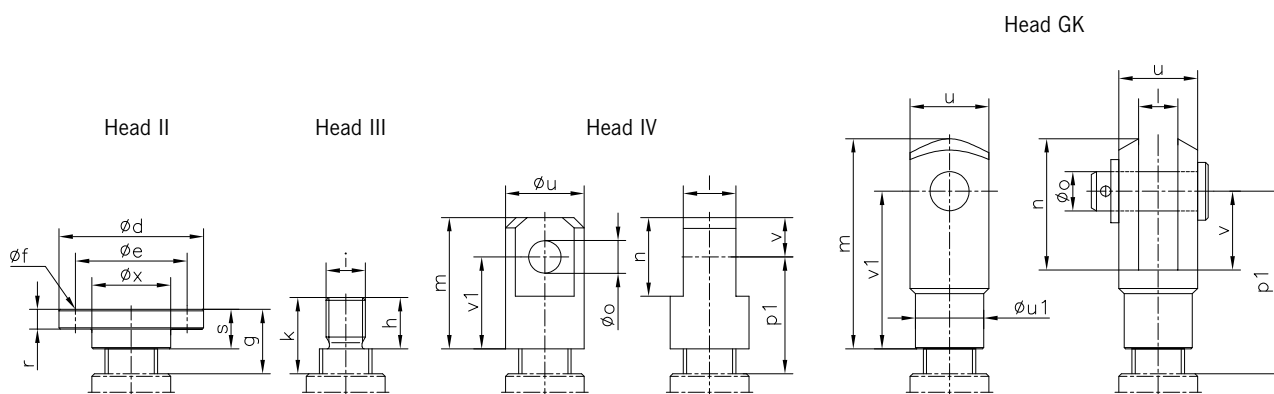

CAD & go



A



MERKUR range

Dimensions: Type 1

Dimensions MERKUR: Type 1, Standard

Size Screw*	M 0	M 1	M 2	M 3	M 4	M 5	M 6	M 7	M 8
	Tr 14x4	Tr 18x4	Tr 20x4	Tr 30x6	Tr 40x7	Tr 60x9	Tr 80x10	Tr 100x10	Tr 120x14
	-	Ku 16x05 Ku 16x10 Ku 16x20	Ku 20x05	Ku 25x05 Ku 25x10 Ku 25x25	Ku 40x05 Ku 40x10 Ku 40x20	Ku 50x10	-	-	-
A/A **	25/55	25/55	35/65	40/75	45/100	55/90	60/110	65/155	100/145
B	77	97	120	132	182	255	275	360	466
C	25	31	37,5	41	58,5	80	82,5	110	133
D	60	80	100	130	180	200	240	290	360
E	48	60	78	106	150	166	190	230	290
F	50	72	85	105	145	165	220	250	300
G	38	52	63	81	115	131	170	190	230
H	M6	M8	M8	M10	M12	M20	M30	M36	M42
Ø J k6	9	10	14	16	20	25	30	35	48
K1	20	25	32	45	63	71	80	100	135
K2	16	21	29	42	63	66	75	95	115
L	22	31	40	54	78	83	100	125	150
L1	20	22,5	25,5	43	45	65	65	63	97,5
L2	12	13	15	15	16	30	45	54	80
N	92	120	140	195	240	300	355	380	500
P	62	74	93	105	149	200	205	270	326
Q	3x3x14	3x3x18	5x5x20	5x5x36	6x6x36	8x7x56	8x7x56	10x8x56	14x9x90
T	12	12	18	23	32	40	40	50	60
Ø U	28	32	40	50	65	90	125	150	180
Ø V	24x24	Ø48	Ø56	Ø56	Ø78	Ø78	Ø110	Ø115	Ø120
V1	M5	M4	M5	M5	M6	M6	M10	on request	on request
Ø W	26	30	38,7	46	60	85	120	145	170
Y	50	62	75	82	117	160	165	220	266
Head II									
Ø d	50	65	80	90	110	150	220	260	310
Ø e	40	48	60	67	85	117	170	205	240
Ø f	4xØ7	4xØ9	4xØ11	4xØ11	4xØ13	4xØ17	4xØ25	4xØ32	4xØ38
g	19	24	28	28	34	57	72	92	142
s	16	20	21	23	30	50	60	80	120
r	6	7	8	10	15	20	30	40	40
Ø x	26	30	40	46	60	85	120	145	170
Head III									
h	12	19	20	22	29	48	58	78	118
i	M8	M12	M14	M20	M30	M36	M64x3	M72x3	M100x3
k	15	23	27	27	33	55	70	90	140
Head IV									
l h10	12	15	20	30	35	40	80	110	120
m	40	55	63	78	105	147	175	220	330
n	20	30	36	45	65	83	130	170	230
Ø o H8	10	14	16	24	32	40	60	80	90
p1	33	44	52	58	74	104	117	147	222
Ø u	25	30	40	45	60	85	120	160	170
v	10	15	18	25	35	50	70	85	130
v1	30	40	45	53	70	97	105	135	200
Head GK									
l H13	8	12	14	20	30	36	-	-	-
m	42	62	72	105	160	188	-	-	-
n	26	37	44	65	100	116	-	-	-
Ø o H9	8	12	16	20	30	35	-	-	-
p1	35	52	63	85	124	151	-	-	-
u	16	24	27	40	60	70	-	-	-
Ø u1	14	20	24	34	52	60	-	-	-
v	16	24	28	40	60	72	-	-	-
v1	32	48	56	80	120	144	-	-	-

* Dimensions for Ku spindle on request

** Screw with anti-rotation device or screw for KGT design

A



MERKUR range

Technical drawings and dimensions

Guide ring Sf



The Sf guide ring is standard on all sizes of the MERKUR series.

With added-on limit switches Sm/Si

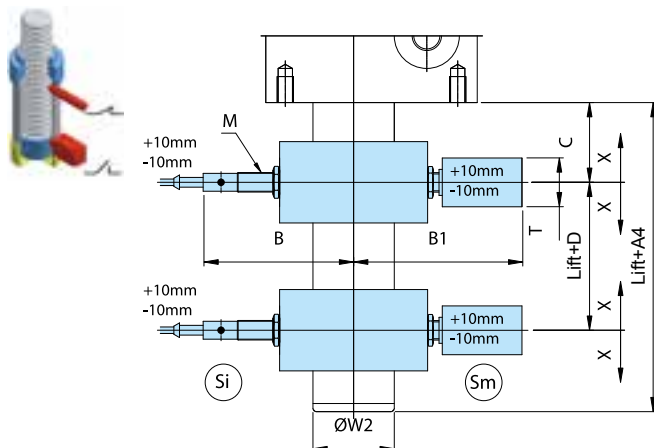

Size	A4	B	B1	C Sm/Si	D Sm/Si	T	M	Ø W2	X
M 0	105	84	95	44/38	12/24	50	M12x1	28	±10
M 1	105	86	97	44/38	12/24	50	M12x1	32	±10
M 2	110	90	100	44/38	16/28	50	M12x1	40	±10
M 3	115	94	104	49/43	16/28	50	M12x1	50	±10
M 4	135	101	111	58/52	20/32	50	M12x1	65	±10
M 5	140	114	123	66/60	20/32	50	M12x1	90	±10
M 6	135	on request		66/60	25/37	50	M12x1	125	±10
M 7	170			76/70	30/42	50	M12x1	150	±10
M 8	160			86/80	30/42	50	M12x1	180	±10

All sizes are prepared for mechanical (Sm) and inductive (Si) operating limit switches. Limit switches are not included in the scope of delivery.

Ind. proximity switch Si
IF-0006

Mechanical limit switch Sm
XCM D 21F2L1

Anti-Turn device V

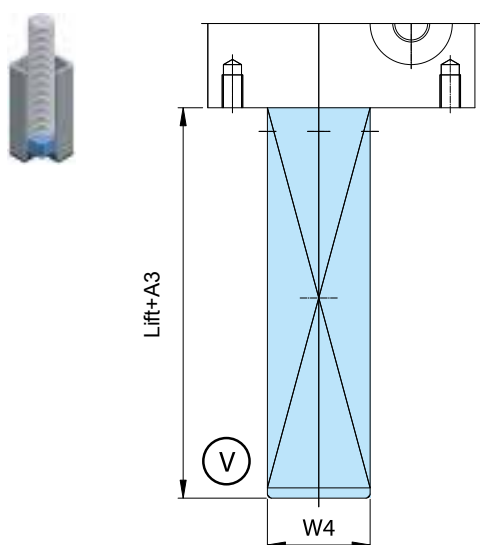

Size	A3	W4
M 1	60	35x35
M 2	70	40x40
M 3	80	50x50
M 4	100	70x70
M 5	115	90x90
M 6	120	125x125
M 7	125	150x150
M 8	155	180x180

In order to ensure a linear movement, the screw must be secured against rotation. This can be done on site or by means of an anti-rotation device on the MERKUR by means of a square tube.

A



B



C

D

MERKUR range

Technical drawings and dimensions

Anti-turn device Vm/Vi with added-on limit switches

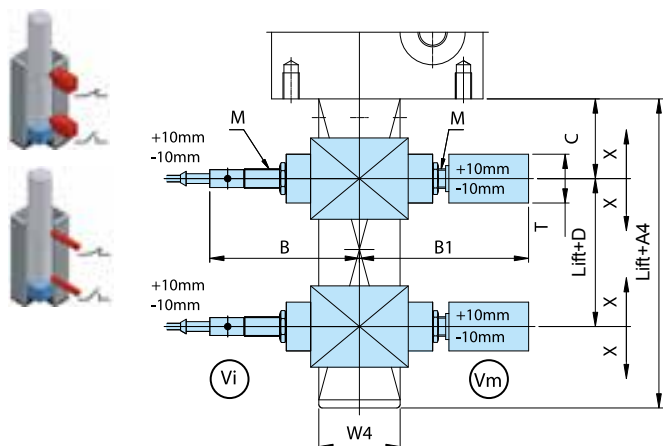

Size	A4	B	B1	C Vm/Vi	D Vm/Vi	T	M	W4	X
M 1	105	86	96	44/38	12/24	50	M12x1	35x35	±10
M 2	110	88	100	44/38	16/28	50	M12x1	40x40	±10
M 3	115	93	105	49/43	16/28	50	M12x1	50x50	±10
M 4	135	101	110	58/52	20/32	50	M12x1	70x70	±10
M 5	145	113	125	66/60	20/32	50	M12x1	90x90	±10
M 6	135	on request		66/60	25/37	50	M12x1	125x125	±10
M 7	170	on request		76/70	30/42	50	M12x1	150x150	±10
M 8	160	on request		86/80	30/42	50	M12x1	180x180	±10

All sizes are prepared for mechanical (Vm) and inductive (Vi) operating limit switches. Limit switches are not included in the scope of delivery.

Ind. proximity switch Vi

IF-0006

Mechanical limit switch Vm

XCM D 21F2L1

Mounting brackets

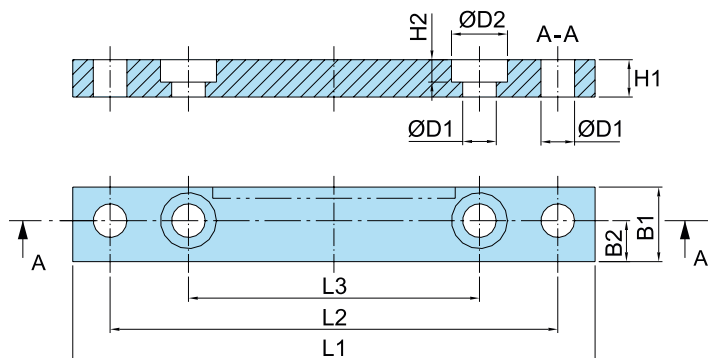

Size	L1	L2	L3	B1	B2	H1	H2	ØD1	ØD2
M 0	90	75	48	12	6	10	5	6,6	11
M 1	120	100	60	20	10	10	5	9	15
M 2	140	120	78	20	11	10	6	9	15
M 3	170	150	106	25	12	12	7	11	18
M 4	230	204	150	30	15	16	8	13,5	20
M 5	270	236	166	40	17	25	14	22	33
M 6	on request								
M 7	on request								
M 8	on request								

A



B



C

D

MERKUR range

Technical drawings: Type 2

Technical drawings MERKUR: Type 2, Standard

A



Head I

Travelling nut LFM

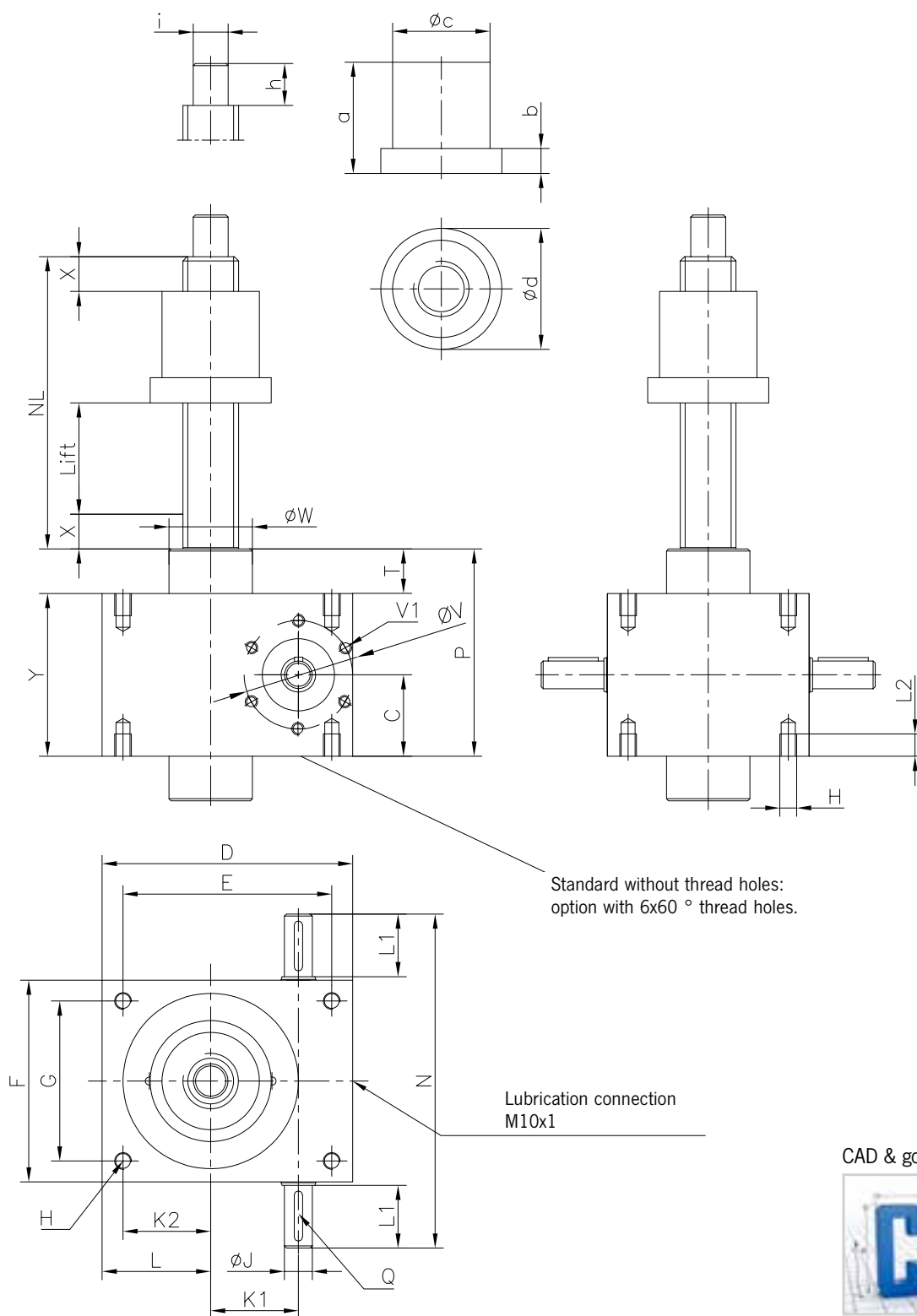

Standard without thread holes:
option with 6x60 ° thread holes.

Lubrication connection
M10x1

CAD & go



MERKUR range

Dimensions: Type 2

Dimensions MERKUR: Type 2, Standard

Size	M 0	M 1	M 2	M 3	M 4	M 5	M 6	M 7	M 8
Screw	Tr 14x4	Tr 18x4	Tr 20x4	Tr 30x6	Tr 40x7	Tr 60x9	Tr 80x10	Tr 100x10	Tr 120x14
C	25	31	37,5	41	58,5	80	82,5	110	133
D	60	80	100	130	180	200	240	290	360
E	48	60	78	106	150	166	190	230	290
F	50	72	85	105	145	165	220	250	300
G	38	52	63	81	115	131	170	190	230
H	M 6	M 8	M 8	M 10	M 12	M 20	M 30	M 36	M 42
Ø J k6	9	10	14	16	20	25	30	35	48
K1	20	25	32	45	63	71	80	100	135
K2	16	21	29	42	63	66	75	95	115
L	22	31	40	54	78	83	100	125	150
L1	20	22,5	25,5	43	45	65	65	63	97,5
L2	12	13	15	15	16	30	40	54	80
N	92	120	140	195	240	300	355	380	500
NL	Lift + 52	Lift + 56	Lift + 70	Lift + 85	Lift + 110	Lift + 125	Lift + 170	Lift + 195	Lift + 215
P	62	74	93	105	149	200	205	270	326
Q	3x3x14	3x3x18	5x5x20	5x5x36	6x6x36	8x7x56	8x7x56	10x8x56	14x9x90
T	12	12	18	23	32	40	40	50	60
T1*	12	12	18	23	32	40	40	50	60
Ø V	24x24	Ø48	Ø56	Ø56	Ø78	Ø78	Ø110	Ø115	Ø120
V1	M5	M4	M5	M5	M6	M6	M10	on request	on request
Ø W	26	30	36,1	46	60	85	120	145	170
Ø W1*	26	30	38,7	46	60	85	120	145	170
Safety X	10	12	15	20	25	25	25	25	30
Y	50	62	75	82	117	160	165	220	266
Travelling nut LFM									
a	32	32	40	45	60	75	120	145	155
b	10	10	12	15	18	25	35	35	50
Ø c h9	40	40	45	50	70	90	130	150	160
Ø d	50	50	65	80	87	110	155	190	225
Head I									
h	12	15	20	25	30	45	75	100	120
Ø i j6	8	12	15	20	25	40	60	80	95

* Bearing neck can be omitted for MERKUR 0 to MERKUR 5 on request.
For other nut designs, see page 94–97

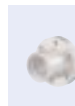
A

B

C
D

MERKUR range

Technical drawings and dimensions

A

With short safety nut LFM-K



The short safety nut significantly increases the operational safety of the drive elements by absorbing the axial load in the event of a main nut fracture. At the same time, the safety nut can be used to check the wear of the main nut exactly, since the distance between the two nuts changes with increasing

wear. In the case of worm gear screw jacks with safety nuts the main load direction (tensile or compression load) and the installation position must always be taken into account, as only a consistently arranged safety nut can take up the load.

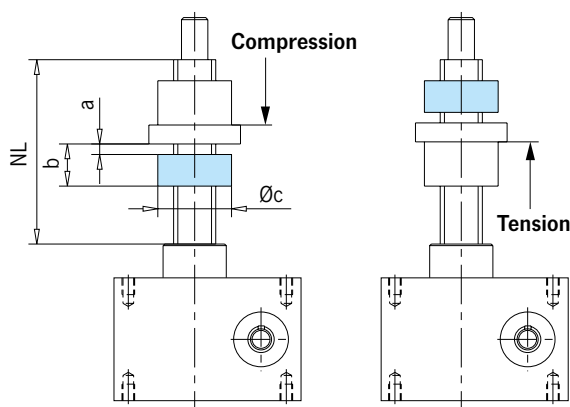

MERKUR type 2, compression and tensile load

Size	NL	a*	b	Øc
M 0	on request			
M 1	on request			
M 2	Lift + 95	5	25	45
M 3	Lift + 120	5	35	50
M 4	Lift + 150	5	40	70
M 5	Lift + 185	5	60	90
M 6	Lift + 250	5	65	130
M 7	on request			
M 8	on request			

*Corresponds to new condition

B

With long safety nut LFM-E (DGV V17/18 and DGV R100-500, chap. 2.10)

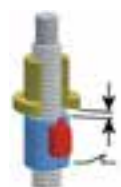

When using worm gear screw jacks in theater stages (DGV V17/18), lifting platforms (DGV R100-500, chap. 2.10) or lifting systems where there is a risk of injury to persons, the screw jacks are designed in accordance with the current regulations.

Additional components ensure, among other things, fall protection (self-locking spindles and/or mechanical safety brakes in the drive) and, if required, the synchronous direction of rotation.

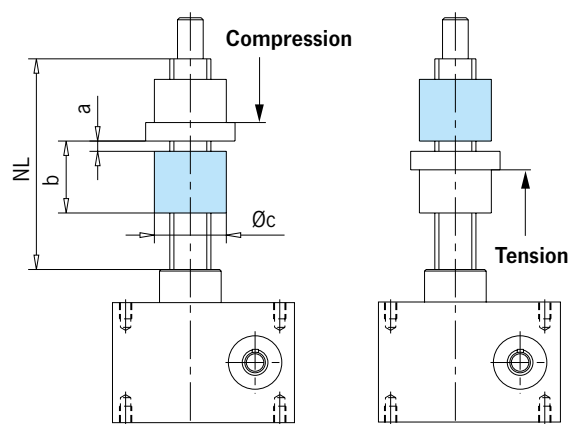

MERKUR type 2, compression and tensile load

Size	NL	a*	b	Øc
M 0	on request			
M 1	on request			
M 2	Lift + 115	5	45	45
M 3	Lift + 140	5	55	50
M 4	Lift + 180	5	70	70
M 5	Lift + 210	5	85	90
M 6	on request			
M 7	on request			
M 8	on request			

*Corresponds to new condition

All sizes are prepared for mechanical operating limit switches. Limit switches are not included in the scope of delivery.

Mechanical limit switch

Technical data and dimensions see chapter „Accessories“!

For further travelling nut designs, see page 94–97

C

D

Screw jacks

Application

Reference example

The „floating“ stage in Lake Idroscalo in Milan has numerous technical refinements – such as a stage roof that can be raised or lowered as required. The construction of Columbus McKinnon not only meets the high safety requirements according to DGUV V17/18 (BGV C1), which apply to the protection of the actors in particular stage technology, but also masters the extreme environmental conditions: The roof lift construction, which can be lifted and lowered with Pfaff-silberblau drive technology, resists precipitation and the humidity of the lake, defies high heat and minus temperatures and ensures absolute safety and smooth functioning even in strong gusts of wind.

The drive system consists of four optimized screw jacks of the SHE series with reinforced saw thread spindles and long, electrically monitored safety nuts. Two of these special SHEs were mechanically coupled and installed on the double shears to the left and right of the stage. Due to the limited space in the scissor construction, the spindle lifting elements were reinforced for a maximum load of 150 tons each. The two drive trains thus have a total lifting force of 6,000 kN distributed over four lifting elements.

This ensures that the screw jacks with a total drive power of around 2 x 18.5 kW can move a load of 500 t at a lifting speed of around 90 mm/min. The long, electrically monitored safety nuts ensure the highest possible safety: In the event of a nut break, a mechanical, forced-opening limit switch switches off the system. The electrical synchronization of the drives takes place via a pulse cam in the safety nut, which transmits an exactly predetermined number of pulses over the entire stroke path via an inductive limit switch to the controller. This PLC control, which was also supplied by Pfaff-silberblau, ensures a corresponding evaluation. Infrared temperature sensors in the lifting elements automatically switch off the system in the event of overload or overheating. An additional plus in safety is provided by a balancing beam, which ensures an even load distribution of the individual pairs of screw jacks.



Optimized worm gear screw jacks from Pfaff-silberblau reliably and, above all, safely raise and lower the roof of Milan's lake stage.
Image source: Pfaff-silberblau

A



B



C



D

MERKUR range

Mounting positions, shaft/attachment side

MERKUR range: Design A

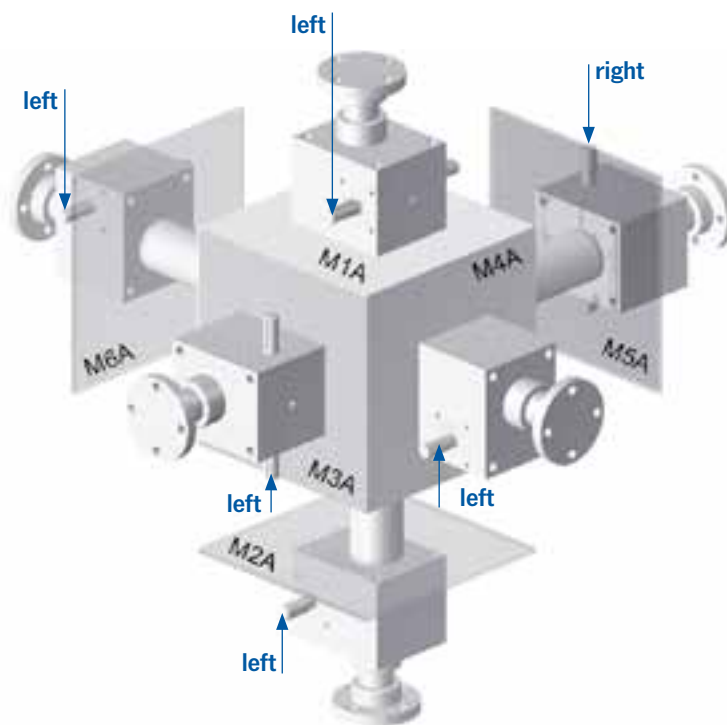

MERKUR range: Design B

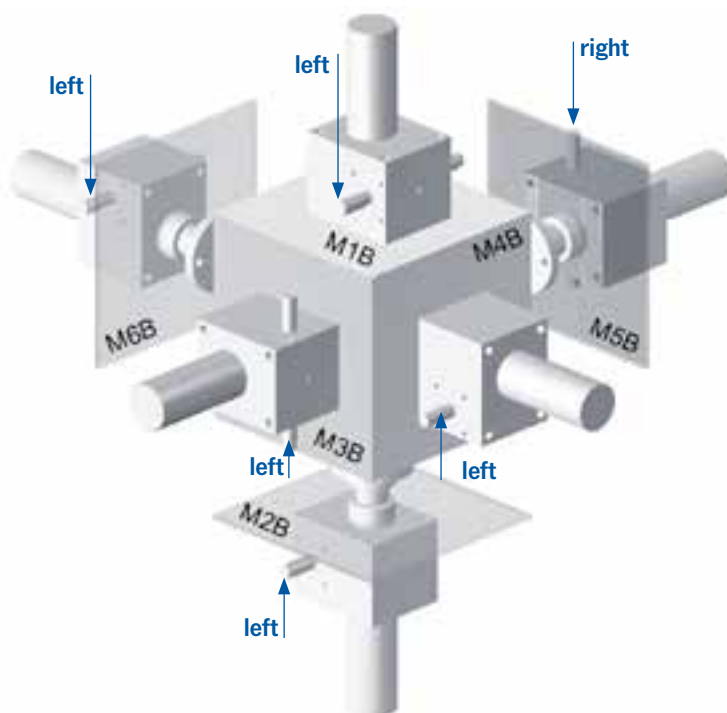

A



B

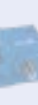

C

D

