

lifting points welded on boltable plates

Safety instructions

This safety instruction/declaration of the manufacturer has to be kept on file for the whole lifetime of the product.
Translation of the Original instructions



RUD Ketten
Rieger & Dietz GmbH u. Co. KG
73428 Aalen/Germany
Tel. +49 7361 504-1371-1314-1527
Fax +49 7361 504-1460
www.rud.com
info@rud.com

RUD-Art.-Nr.: 8502250-EN / 06.012

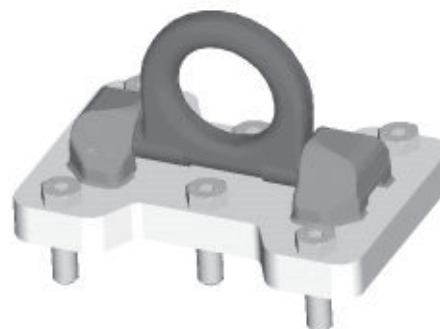

lifting points welded on boltable plates



EG-Konformitätserklärung

entsprechend der EG-Maschinenrichtlinie 2006/42/EG, Anhang II A und ihren Änderungen

Hersteller: **RUD Ketten**
Rieger & Dietz GmbH u. Co. KG
Friedensinsel
73432 Aalen

Hiermit erklären wir, dass die nachfolgend bezeichnete Maschine aufgrund ihrer Konzipierung und Bauart, sowie in der von uns in Verkehr gebrachten Ausführung, den grundlegenden Sicherheits- und Gesundheitsanforderungen der EG-Maschinenrichtlinie 2006/42/EG sowie den unten aufgeführten harmonisierten und nationalen Normen sowie technischen Spezifikationen entspricht.
Bei einer nicht mit uns abgestimmten Änderung der Maschine verliert diese Erklärung ihre Gültigkeit.

Produktbezeichnung: Anschlagpunkt
VRBS/VLBS auf Platte

Folgende harmonisierten Normen wurden angewandt:
EN 12100-1 _____ EN 12100-2 _____
EN 14121-1 _____ EN 1677-1 _____

Folgende nationalen Normen und technische Spezifikationen wurden außerdem angewandt:
BGR 500, KAP2.8 _____

Für die Zusammenstellung der Konformitätsdokumentation bevollmächtigte Person:
Reinhard Smetz, RUD Ketten, 73432 Aalen

Aalen, den 19.05.2010 Dr. Ing. Rolf Sinz, (Prokurist/QMB)
Name, Funktion und Unterschrift Verantwortlicher



EC-Declaration of conformity

According to the EC-Machinery Directive 2006/42/EC, annex II A and amendments

Manufacturer: **RUD Ketten**
Rieger & Dietz GmbH u. Co. KG
Friedensinsel
73432 Aalen

We hereby declare that the equipment sold by us because of its design and construction, as mentioned below, corresponds to the appropriate, basic requirements of safety and health of the corresponding EC-Machinery Directive 2006/42/EC as well as to the below mentioned harmonized and national norms as well as technical specifications.
In case of any modification of the equipment, not being agreed upon with us, this declaration becomes invalid.

Product name: Lifting point
welded on boltable plates

The following harmonized norms were applied:
EN 12100-1 _____ EN 12100-2 _____
EN 14121-1 _____ EN 1677-1 _____

The following national norms and technical specifications were applied:
BGR 500, KAP2.8 _____

Authorized person for the configuration of the declaration documents:
Reinhard Smetz, RUD Ketten, 73432 Aalen

Aalen, 19.05.2010 Dr. Ing. Rolf Sinz, (Prokurist/QMB)
Name, function and signature of the responsible person

User Instruction

1. Reference should be made to German Standards accord. BGR 500 or other country specific statutory regulations and inspections are to be carried out by competent persons only.

2. Before installation and every use, visually inspect RUD lifting points, paying particular attention to any evidence of corrosion, wear, weld cracks and deformations. Please ensure compatibility of bolt thread and tapped hole.

3. The material construction to which the lifting point will be attached should be of adequate strength to withstand forces during lifting without deformation. The German testing authority BG, recommends the following minimum for the bolt lengths:

- 1 x M in steel (min. quality S235JR [1.0037])
 - 1.25 x M in cast iron (e.g. GG25)
 - 2 x M in aluminium
 - 2.5 x M in aluminium-magnesium alloys
- (M = thread Ø, e.g. M 20)

When lifting light metals, nonferrous metals and cast iron the thread has to be chosen in such a way that the WLL of the thread corresponds to the requirements of the corresponding base material.

The lifting points will be supplied by RUD with a crack-detected connecting bolt. **In case of using own bolts, these have to be tested for being 100 % crack-free.** At minimum, a bolt has to be used having the quality mentioned on the connecting plate and the prescribed diameter.

4. The lifting points must be positioned to the load in such a way that movements are avoided during lifting.

a.) For single leg lifts, the lifting point should be vertically above the centre of gravity of the load.

b.) For two leg lifts, the lifting points must be equidistant to/or above the centre of gravity of the load.

c.) For three and four leg lifts, the lifting points should be arranged symmetrical around the centre of gravity in the same plane if possible.

5. Load symmetry:

The required WLL of the individual RUD lifting point are calculated using the following formula and are based on symmetrical loading:

$$W_{LL} = \frac{G}{n \times \cos \beta}$$

W_{LL} = working load limit / capacity of each lifting point
 G = load weight (kg)
 n = number of load bearing legs
 β = angle of inclination of the chain to the vertical

The calculation of the load bearing legs is as follows:

	symmetrical	unsymmetrical
Two leg	2	1
Three/four leg	3	1

(also refer to table 1)

6. A plane surface must be guaranteed. The hole must be drilled with a sufficient depth in order to guarantee compatibility with the supporting surface.

7. For single straight pull use just tighten with spanner. For long term application or using the lifting points under inclination angle conditions the tightening has to be done with the torque mentioned on the plate.

The permissible weight of load for the different loading methods has to be defined by the user (authorised and trained person) according to the WLL indication on the connecting plate and the factors mentioned in table 1.

With turning processes and in permanent operation, the bolts have to regularly be examined with regard to their torque prescribed (for turning processes, we recommend to use the RUD lifting point PowerPoint VWBG-V or VWBG).

8. All fittings connected to the Lifting point should be free moving. Also the assembled components on the Lifting point must be free moveable and should not used over sharp corners.

When connecting and disconnecting the lifting means (wire ropes, chain slings, roundslings) pinches and impacts should be avoided. Damage of the lifting means caused by sharp corners should be avoided as well.

9. To prevent unintended dismounting through shock loading, rotation or vibrations thread locking devices are recommended. Therefore different locking systems are possible. Liquid locking fluid such as Loctite (respect manufacturer specifications) or form closed versions such as hex castel nut, counter nut, etc.

10. Effect of temperature:

For the lifting points with plate, the WLLs have to be reduced according to the strength class of the bolts as follows, due to the DIN/EN bolts used:

100° to 200°C minus 15 % 212°F to 392°F

200° to 250°C minus 20 % 392°F to 482°F

250° to 350°C minus 25 % 482°F to 662°F

Temperatures above 350°C (662°F) are not permitted.

11. RUD-Lifting points must not be used under chemical influences such as acids, alkaline solutions and vapours e.g. pickling baths or hot dip galvanising plants.

12. The position where the lifting points should be attached should be clearly marked with colour.

13. If the lifting points are used **exclusively** for lashing the value of the working load limit can be doubled. $LC = 2 \times WLL$

14. After fitting, an annual inspection or sooner if conditions dictate should be under taken by a competent person examining the continued suitability. Also after damage and special occurrences.

Inspection criteria regarding paragraphs 2 and 14:

- Ensure correct bolt size, quality and length
- Ensure compatibility of bolt thread and tapped hole
- The lifting point should be complete
- The WLL, thread size, torque, batch code and manufacturers stamping should be clearly visible on the lifting point.
- Deformations at bearing parts such as connecting plate, suspension bracket and bolts.
- Mechanical damages such as notches, especially in high stress areas.
- Wear should be not more than 10 % of cross sectional diameter.
- Evidence of corrosion.
- Evidence of cracks
- Damage to the bolt and/or thread

A non-adherence to this advice may

result damages of persons and materials!

Method of lift										
Number of legs	1	1	2	2	2	2	2	3 and 4	3 and 4	3 and 4
Angle of inclination β	0°	90°	0°	90°	0-45°	45-60°	unsymm.	0-45°	45-60°	unsymm.
Factor	1	1	2	2	1.4	1	1	2.1	1.5	1
WLL stamped in plate	WLL in metric tonnes									
e.g. 1000 kg	1.0 t	1.0 t	2.0 t	2.0 t	1.4 t	1.0 t	1.0 t	2.1 t	1.5 t	1.0 t
e.g. 5 t	5.0 t	5.0 t	10.0 t	10.0 t	7.0 t	5.0 t	5.0 t	10.5 t	7.5 t	5.0 t
e.g. 10 t	10.0 t	10.0 t	20.0 t	20.0 t	14.0 t	10.0 t	10.0 t	21.0 t	15.0 t	10.0 t
e.g. 31.5 t	31.5 t	31.5 t	63.0 t	63.0 t	45.0 t	31.5 t	31.5 t	67.0 t	47.5 t	31.5 t
e.g. 50 t (e.g. VRBG-50)	50 t	50 t	100 t	100 t	70 t	50 t	50 t	105 t	75 t	50 t

Table 1