

>PSA-VRS<
>PSA INOX STAR<
M12 (1 Pers.)

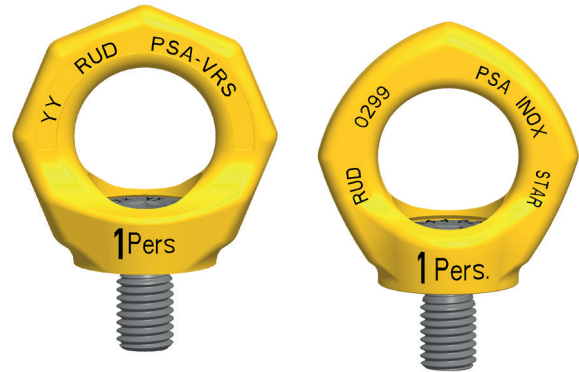

Safety instructions

This safety instruction/declaration of the manufacturer has to be kept on file for the whole lifetime of the production.
Translation of the Original instructions



RUD Ketten
Rieger & Dietz GmbH u. Co. KG
73428 Aalen
Tel. +49 7361 504-1370
Fax +49 7361 504-1171
sling@rud.com
www.rud.com

RUD-Art.-Nr.: 7905318-EN / 02.017

VIP-Eye bolt
PSA-VRS
M12 (1 Pers.)
Eye bolt made out of stainless
Duplex-steel
PSA INOX STAR
M12 (1 Pers.)

EC-Declaration of the manufacturer	
According to the European Directive 89/686/EWG and amendments	
Manufacturer:	RUD Ketten Rieger & Dietz GmbH u. Co. KG Friedensinsel 73432 Aalen
We hereby declare that the equipment, as mentioned below, corresponds to the appropriate, basic requirements of safety and health of the corresponding European Directive for "personnel protection equipment" 89/686/EWG in the design as it is sold by us because of its design and construction. In case of any modification of the equipment, not being agreed upon with us, this declaration becomes invalid.	
Product name:	<u>Anchor device</u> PSA-VRS / PSA-INOX-STAR
The following harmonized norms were applied:	
DIN CEN/TS 16415 : 2013-04	DIN EN 50308 : 2004
DIN EN 795 : 2012-10	DIN EN ISO 12100 : 2011-03
EN 365 : 2004-12	
The following national norms and technical specifications were applied:	
AS/NZS 5532 : 2013	BGR 198
OSHA 1926.502	
Notifying department:	FA PSA Test- and Certification department of BG-PRÜFZERT Identification No.: 0299
Authorized person for the configuration of the declaration documents:	Michael Betzler, RUD Ketten, 73432 Aalen
Aalen, den 05.10.2016	Dr.-Ing. Arne Kriegsmann, (Prokurist/QMB) Name, function and signature of the responsible person

Testing regulation:

EN 795:2012-10 und EN 795:1996-08
DIN EN 50308:2004 Abs. 4.5, 2008-11
OSHA 1926.502 (d)(15)

Notifying department:

FA PSA Test- and
Certification department
of DGUV Test

Zwengenberger Straße 68
42781 Haan

Identification No: **0299**



Before every use, please read the Safety Instruction of the PSA-Fall protection anchorage point (PSA-VRS / PSA INOX STAR M12) carefully and make sure that you understand all substance.

Improper use or care of this eyebolt can result in bodily injury or property damage and eliminates any warranty!

1 Application and warning information



WARNING

Improper assembled or damaged fall protection anchorage points and inappropriate use can result in deadly injury or lead to heavy injuries when load drops.

Inspect fall protection anchorage points before each use carefully!

- PSA-VRS and PSA INOX STAR M12 must only be used by competent and trained people with adequate knowledge, and outside Germany the corresponding country specific requirements must be utilised.
- **PSA-VRS M12 is not suitable for permanent outdoor use. Changing weather conditions can cause corrosion and wear of material.**
- The user of the PSA-Fall protection anchorage point must be in good health to use this equipment. The hereby necessary certification can f.e. be verified by a G41-checkup.
- The PSA-Fall protection anchorage points must only be loaded with the stated number of persons.
- To enable safety and appropriate information for all users in case of a resell to an other country, the reseller must provide the user instruction, maintenance instruction for the regular inspection and the repairing in the country specific language.

2 Intended use of PSA-VRS and PSA INOX STAR

PSA-VRS and PSA INOX STAR M12 eyebolt can be used as anchor point, for fall protection harnesses. This anchor point (subsequently named PSA-Fall protection anchorage point) can also be attached permanent to a building, so that a fall protection harness can be hooked in.

PSA-Fall protection anchorage points must only be used as fall arrest equipment (and not for lifting purposes).

PSA-Fall protection anchorage points **are not designed to be used for permanent swiveling under load**, because they can turn loose when turned under load. Please observe the following WLL:

PSA-VRS M12 and PSA INOX STAR M12 are permissible for max.1 Person

RUD-PSA (lifting points) fixing points are able to take all possible occurring forces in any loading directions if used in the intended way as fall arrest protection devices.

PSA-VRS M12 is not suitable for permanent outdoor use. Changing weather conditions can cause corrosion and wear of material.

In consequence of the assembly method this product fulfills the requirements as described in DIN EN 795 paragraph 3.2.1:

Fall protection anchorage device type A

Fall protection anchorage device which includes when installed, either one or multiple stationary anchor point(s) and if for their fixing at the structural facility a stationary installed anchor point or a fixing element is necessary.

The PSA-VRS eyebolt and the PSA INOX STAR M12 must only be used for the in the user instruction specified purposes.

3 Installation information

3.1 General information

- Capability of temperature usage:
The PSA-Fall protection anchorage points PSA-VRS and PSA INOX STAR M12 can be used in the temperature range between -40°C up to 280°C.
- RUD PSA-Fall protection anchorage points must not be used under chemical influences such as acids, alkaline solutions and vapours. Please observe chapter 2, Intended use of *PSA-VRS and PSA INOX STAR*.
- Pay attention during transport and storage of the PSA fall arrest anchor point that the thread will not be damaged.



HINT

The bolt is hold captive in the housing by 4 compressions (indentations).

- A plan must exist to accomplish rescue actions, including all kinds of possible emergencies occurring with the work.
- If the PSA-Fall protection anchorage point is used in mobile applications, it must be handed out to the user personally.
- Modifications or repairing on the PSA-Fall protection anchorage points must be carried out by the manufacturer only.
- Store fall protection eyebolt at dry and non corrosive environment only.
Correct maintenance and storage are important for the safety of the worker.

3.2 Assembly information

1. The material construction to which the PSA-Fall protection anchorage points will be attached should be of adequate strength to withstand forces during lifting without deformation (certificate of static forces). Employer's insurance association recommends the following minimum engagement length for the bolts:

- 1 x M in steel (min. grade S235JR [1.0037])
- 1,5 x M in grey cast iron (f.e. GG 25)
- 2 x M in aluminium alloys
- 2,5 x M for light metals of low strength (M = size of thread, f.e. M12, means 12 mm thread diameter)

When used in light metals, nonferrous metals and grey cast iron or other materials the thread has to be chosen in such a way that the WLL of the thread corresponds to the requirements of the corresponding base material.



HINT

RUD-PSA-Fall protection anchorage points are standard wise supplied with a thread lengths of 1,5 x M. Make sure that the tapped hole is providing enough depth (see also chapter 3.2 Hints for the assembly – point 5).

If the PSA fall arrest anchor point will be attached to a through hole, the bore must be carried out according to DIN EN 20273 range „m“. When using a nut please choose a commercially available lock-nut acc. to DIN EN ISO 7042 with washer or use a equivalent bolt securing device to avoid unintentional loosening of screw joint. Should a disassembly of the lock-nut become necessary, it is mandatory to use a new lock-nut and the thread of the bolt must be inspected.

2. The bolting location for the PSA-Fall protection anchorage points should be marked with paint.
3. The PSA-Fall protection anchorage point should be installed as follows:
 - Position above the user (this does not exclude other installation positions) reduces risk of tripping, the height of fall and swinging after a tumble.
 - the coupling element must be free moveable,
 - the coupling element must not be loaded over edges
4. Make sure that a plane bolting surface is provided ($\varnothing E$, see chart 2). Maximum countersink of the threaded hole = Nominal diameter of thread.
5. Drill the tapped blind holes deep enough so that the shoulder of the PSA-VRS and PSA INOX STAR M12 bolt sits properly on the plane surface. At through holes please consider also DIN EN 20273 middle
6. Fixing in sectional or hollow profile steel can be carried out by using a blind-rivet nut type Rivkle in steel or stainless steel. Here observe the assembly instructions of the manufacturer. When using a **blind-rivet nut from Rivkle** please use **type 343 66 120** with a small counter sunk (see picture 1).

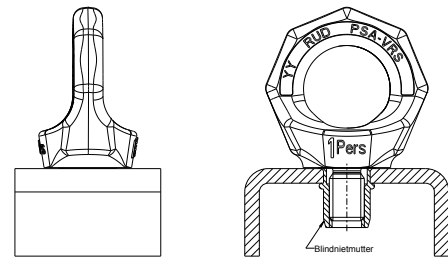

Pict. 1: Blind-rivet nut

Marking of the PSA-VRS and PSA INOX STAR M12

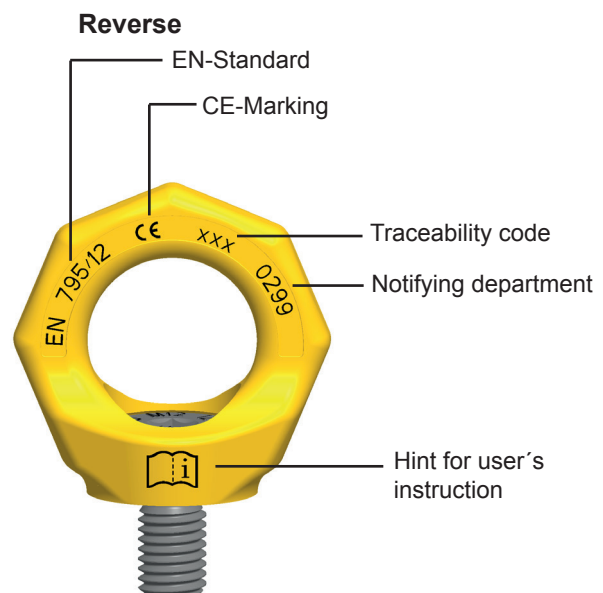
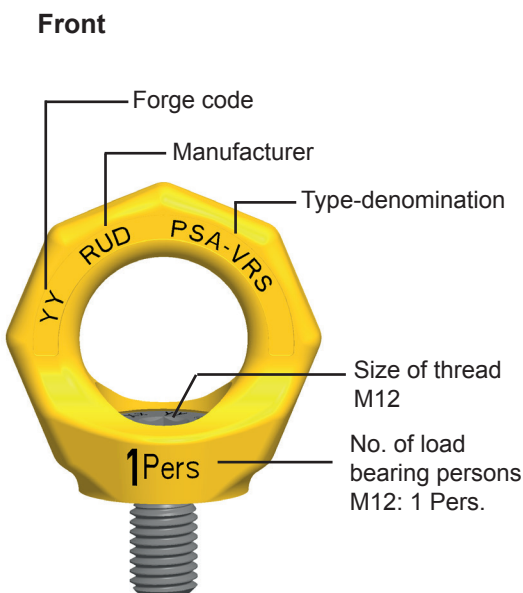

The markings are according to DIN EN 365 „Personal fall protection gear“ – general requirements for user instructions and marking

7. PSA-VRS and PSA INOX STAR M12 must be able to turn by 360° around the bolt axle when its completely installed.

Temporarily installed PSA-Fall protection anchorage point:

For a **temporarily** installation/loading at the load force transmission point, hand tightening of the bolt with an allen key or a suitable tool, applied with normal hand force (approx. 50 daN) into the designed and determined thread is sufficient.

Permanent installed PSA-Fall protection anchorage point:

For an applicable **permanent** installation/loading at the force transmission point, the PSA-Fall protection anchorage points must be bolt in by using a suitable setscrew and a torque wrench into the designed thread. The necessary clamping and fastening torque value (+/- 10 %) can be taken out of chart 1.

It is possible to receive a socket wrench for the usage of a torque:

Type	tightening torque [Nm]	Ref.-No. of key
PSA-M12	25	7997750

Chart 1

As an additional securing the usage of liquid bolt securing f.e. Loctite or WEICONLOCK (observe manufacturer's instruction) should be used. Assembly of the PSA-VRS and PSA INOX STAR M12 eyebolt must only be carried out in such a way that a disassembly can only be done with suitable tools.

3.3 User information

- Inspect PSA-Fall protection anchorage device regularly before each usage in regard of tightening, corrosion, wear, deformation etc. (see chapter 4 Inspection criteria).



WARNING

Wrong assembled or damaged PSA-Fall protection anchorage points as well as incorrect usage may result in serious or deadly injuries.

PSA-Fall protection anchorage points must be in general inspected before each usage.

- If a safe usage is doubtful or if the lifting mean has been stressed by a dropped load, for safety reasons the usage must be withdraw. A competent person must decide whether the lifting mean can be used further on.
- The PSA-Fall protection anchorage point has to be adjustable through 360° when fitted and completely installed.



HINT

Attention: PSA-Fall protection anchorage points M12 eyebolts are not suited for permanent turning under load!

- When composing harness equipment to a disposal system make sure that they are supposed to be put together and that the coupling element is compatible with the fall protection device.
- If the fall arrest anchor device is used as part of a fall protection system, make sure that the following requirements are guaranteed: Devices must be used which are limiting the max. dynamical forces, which can occur to the user during a fall, to max. 6 kN.
- Care should be taken when selecting components of equipment to avoid any risk of injury to persons or damage of property. The safe function of a component or a compromised equipment must not be effected.
- Eliminate any damage of the PSA-Fall protection anchorage point for example caused by loading on sharp edges.
- The assembly of a PSA-Fall protection anchorage point to a coupling element must be done by using coupling elements according to EN 362 (Grade B and M), which have to free moveable to all sides. Any other grades are prohibited. Exception: Grade T is allowed, depending on the shape. Squeezing, tripping, shear and joint locations must be avoided. The coupling element must not be kinking when loaded.
- Karabiner hooks according to DIN 5290 are prohibited.
- For a body harness (belt type) in a fall protection system only harness belts according to EN 361 must be used.
- Make sure when using fall arrest anchor systems that it is decisive for the safety of the user to guarantee that enough space below the working area is existing. In case of a fall there will be no impact at the ground or an obstacle be possible.
- Hook coupling element of the selected harness system into the eye of the PSA-Fall protection anchorage point and lock the coupling accordingly.
- Improper use of the lifting mean cause limitations in regard of the usage period. The system must be inspected and controlled according to chapter 4 of the Inspection criteria.
- In addition to that please observe user instruction of all other components also.

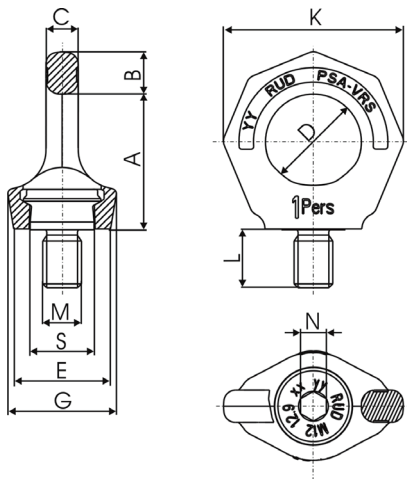

Drawing
PSA-VRS

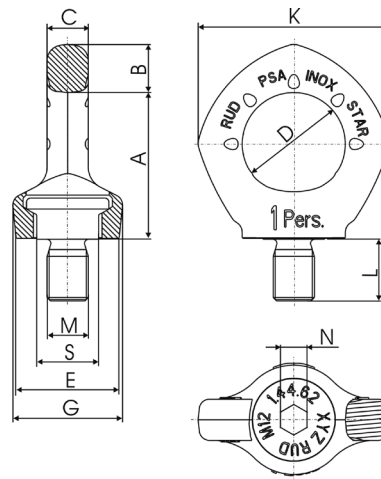

Drawing
PSA INOX STAR

Type	WLL	weight	A	B	C	D	E	G	K	L	M	N	S	Certification-no.	Ident.-No.
PSA-VRS M12*	1 Pers.	0.2 kg	42	13	10	30	30	34	56	18	12	8	18	PS 14060004	7997100
PSA-VRS M12*	1 Pers.		42	13	10	30	30	34	56	18-150	12	8	18	PS 14060004	8600400
PSA-VRS M12	1 Pers.	0.44 lbs	1 ¹¹ / ₁₆ "	1 ¹ / ₂ "	1 ³ / ₃₂ "	1 ³ / ₁₆ "	1 ³ / ₁₆ "	1 ⁵ / ₁₆ "	2 ⁷ / ₃₂ "	3 ³ / ₄ "	12	5 ⁵ / ₁₆ "	2 ³ / ₃₂ "	PS 14060004	7997103
PSA INOX STAR M12*	1 Pers.	0.19 kg	42	14	10	30	30	32	56	18	12	8	18	PS 14060004	7997097
PSA INOX STAR M12*	1 Pers.	0.22 kg	42	14	10	30	30	32	56	50	12	8	18	PS 14060004	7997820

Chart 2

* dimensions in mm

Subject to technical alterations

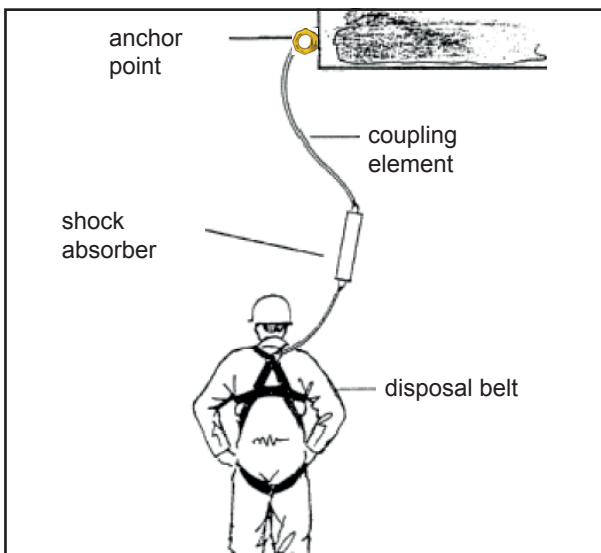

Overview disposal system with shock absorber
(source: BGR/GUV-R 198, 03/2011, page 13 picture 7)

3.4 Hints for the regular inspection

In time periods complying to the need or usage a technical expert should control at least once a year the appropriateness of the anchor point. This inspection must also be done after each event of damage or special incident.

3.5 Hint for the maintenance

For cleaning of PSA-Fall protection anchorage point use only solvent- and acid-free cleaning supplies.

4 Inspection criteria

Observe and control the following points before each usage in regular periods, after assembly and after special incidents (see judgement of hazard, resp. note admitted technical rules):

- The plane area of the eye bolt can completely flat down to the work piece.
- Completeness of the PSA-Fall protection anchorage point
- Complete, readability of the Working Load Limit (WLL) as well as existing sign of manufacturer
- Deformation on load bearing parts like basic body and bolt. Easy turning of the ring, free of jerk must be assured.
- Mechanical damages like notches, especially when located in areas of tensile stress
- strong corrosion
- Inspection of cross section reduction is only necessary if noticeable abnormalities can be seen. In this juncture the 10 % wear reduction regulation becomes valid
- Cracks at load bearing parts
- Function and damage of bolts and threads, if it's visible
- The product identification at the PSA-Fall protection anchorage point must be high visible and easy to read
- Please fill out the documentation card carefully and save it to write down regular inspections and possible reparings.
- If necessary you can leave a mark at the component informing about the latest and up-coming inspection.

5 Inspection card

Produkt:						
Type:		Trade name:			Individual No.: (if available)	
Manufacturer: Address:						
Forge code:						
Sequence of regular inspections						
Date	Inspection	Repairing	OK	Detected fault	Name and signature of technical expert	Date of next regular inspection
 <p><i>Before PSA-Fall protection anchorage points will be used, please read user instruction carefully. Make sure that you understand all the substance. Non-observance of this instruction may cause serious personal injury and/or damage to property!</i></p>						