



MAIN FEATURES

Heavy duty c-shaped steel construction for strength and rigidity with drop forged forks.

Chip and corrosion resistant paint finish

Fixed Forks

Heavy duty pump unit with a lifting capacity of 1000kg

Light and easy steering with foot brake

Conforms to CE standards

An economical solution for lifting and moving pallets, skids, etc.

Open bottom pallets only

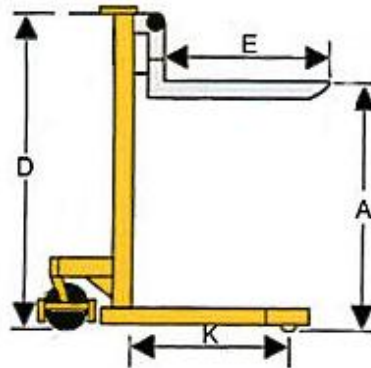
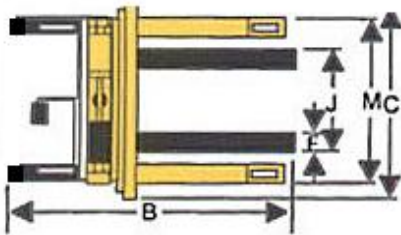

MODEL

SFH1016

Capacity		kg	1000
Max Fork Height	A	mm	1600
Lowered Fork Height		mm	85
Fork Fixed Width	J	mm	550
Fork Width	F	mm	150
Fork Length	E	mm	1150
Overall Length	B	mm	1600
Overall Height	D	mm	1980
Overall Width	C	mm	740
Weight of Unit		kg	240