



## Tiger Twin Hook Air Hoist

### Main Features

- TAH21M 2.0t/2.0t configuration
- TAH33M 3.0t/3.0t and 3.0t/6.0t configurations
- Two chain falls with hooks for alternate working
- Various hook options – standard, closed eye, grab and self-locking
- Integral load limiter
- Especially suitable for horizontal pulling
- Reliable, fast, efficient, quiet and lightweight
- Greater than 5:1 factor of safety
- Certified for ATEX Category 3 – normal safety

Originally designed for mining applications and suitable for both pulling and lifting operations. Now deployed globally in various marine and industrial applications. They comply with the requirements of SANS 1638, EN14492-2 and ASME B30.16. Our manufacturing facility producing the hoists is ISO9001 certified.

### Advantages of Air Hoists

Air-powered hoists are ideal for tasks that require rapid lifting speeds and constant use. These hoists are powered by a compressed air feed, making them a great alternative to electric hoists when there are no power sources available. Another key benefit of air hoists is their 100 % duty cycle - significantly higher than most electric hoists. For example, an electric chain hoist that has a 25 % duty cycle can be operated continuously for a maximum of 15 minutes in a one-hour period. Hoists that are powered by a compressed air feed do not have this limitation; they can remain in constant use until the job is done.

### Load Limiter

Integral differential pressure load limiting valve automatically prevents the operator lifting a load of more than 125 % of the working load limit. Load limiter is 100 % repeatable at all working pressures and does not wear or generate damaging heat.

### Precise Control

Lever control, pilot pendent control and direct pendent control offer variable speed control. Accurate and precise positioning of loads is standard for both toggle and pendant control models. Various lock out options available.

### Fail Safe Disc Brake

Non-asbestos self-adjusting disc brake is applied automatically when the air supply to the hoist is shut off. The brake is self-adjusting for the life of the brake and can hold more than 125 % of the working load limit.

### Integral Silencer

The exhaust air silencer is built into the hoist gearbox housing and limits the noise level to below 83dB(A).

### Load Chain

Grade 8 load chain ensures stringent high speed duty cycles can be met. The load chain is in accordance with the requirements of SANS/ISO 3077 and EN818-7 Appendix B.

### Vane Motor

Assisted vane lifting ensures maximum starting torque when starting under load.

### Sealed Gearbox

The sealed planetary gearbox ensures that the most stringent duty cycles can be met. The gears are heat treated and mounted on high strength, low friction bearings.

**New**

3t/6t with  
twist grip  
pendent

### Ease of Maintenance

The modular design of the hoist allows easy access to internal components such as the motor, gearbox, brake and load limiter. Common parts are used throughout the range.

### ATEX

Manufactured in accordance with ATEX Directive 2014/34/EU and Machinery Directive 2006/42/EC and suitable for ATEX Category 3 – normal safety. Our products are assigned as follows: ATEX marking: : Ex II 3 GD c IIB T4 IIIB T135°C. Suitable for gas and dust hazardous areas: Zone 2 (gas) and Zone 22 (dust). Unlike electrically operated hoists, the air driving pneumatic air hoists doesn't produce any sparks making them suitable for application in explosion-hazardous areas.

### Hook options

Various hook options – standard, closed eye, grab and self-locking



Standard



Closed eye



Grab



Self-locking



3t/6t with toggle control

### Pendent control options

Our air hoists are supplied with our variable control E/stop pendent and the option of our twist grip E/stop pendent which gives perfect control in both directions. Toggle control available as an option.



E/stop



Twist grip E/stop



Toggle control

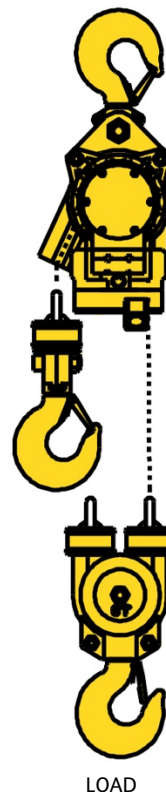

LOAD

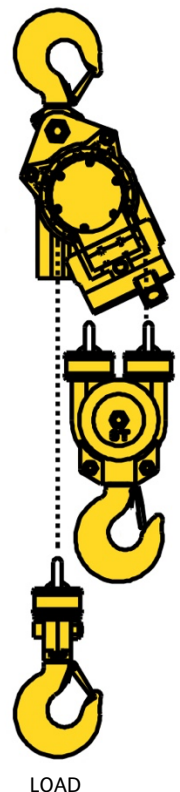

LOAD

### Technical Data

	AHM-021P	AHM-030P	AHM-063P	
Lifting Capacity (tonne)	2.0/2.0	3.0/3.0	3.0/6.0	
Falls of Chain	1/1	1/1	1/2	
Chain Size (mm)	10 x 28	13 x 36	13 x 36	
Total Weight (kg) *	66.0	82.0	102.0	
Full Load Lifting Speed (m/min) @ 6 bar	4.7	4.9	4.9/2.4	
Full Load Lifting Speed (m/min) @ 4 bar	2.6	3.2	3.2/1.6	
No Load Lifting Speed (m/min) @ 6 bar	7.0	6.4	6.4/3.2	
Full Load Lowering Speed (m/min) @ 6 bar	7.5	7.0	7.0/3.5	
No Load Lowering Speed (m/min) @ 6 bar	5.9	5.4	5.4/2.7	
Air Consumption (m <sup>3</sup> /min) @ 6 bar	2.6	4.0	4.0	
Air Consumption (m <sup>3</sup> /min) @ 4 bar	1.7	2.6	2.6	
Air Connection	G <sup>3</sup> / <sub>4</sub>	G <sup>3</sup> / <sub>4</sub>	G <sup>3</sup> / <sub>4</sub>	
Supply Hose (Inside Ø) (mm)	19	25	25	
Sound Level (dB(A)):	83	83	83	
Dimensions (mm)	A	382	466	466
	B	192	215	215
	C	96	108	130
	D	-	-	85
	E	345	345	345
	Min F	537	548	599
	Min G	-	-	689

\* Weight is for 3m HOL, E/Stop pendant control (2m) J-hooks

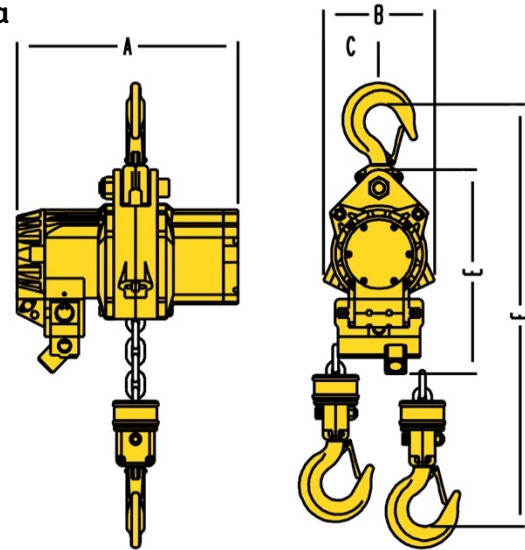

AHM-021P

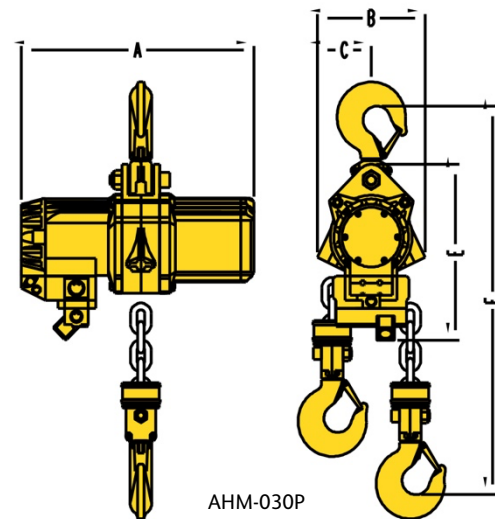

AHM-030P

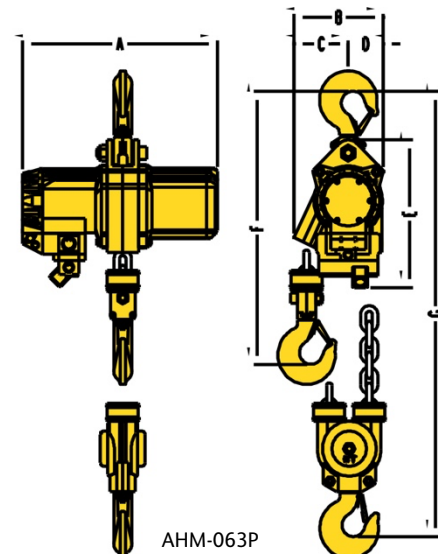

AHM-063P