

Dual Speed Chain Hoist

The William Hackett dual speed chain hoist meets and exceeds the requirements of the following international standards:

British Standard BS EN13157:2004 + A1:2009

American Standard ASME B30.16-2012

Australian Standard AS1418.2-1997

South African Standard SANS 1594:2007

NORSOK R-002: 2017.

The design and specification of the William Hackett dual speed chain hoist includes:

- **WORKING LOAD LIMIT RANGE:** 3.2 tonnes to 50 tonnes.
- **LIGHT LOAD CAPABILITY:** the dual speed chain hoist is tested and certified at 2% of the chain hoist rated capacity.
- **TWIN PAWL:** double safety; fitted as standard.
- **SAFETY LATCHES:** the dual speed chain hoist top and bottom hooks are fitted with heavy duty cast steel latches. The latch and hook tip are integrated creating a strong and robust hook closure.
- **OVERLOAD INDICATOR MARKS:** the dual speed chain block top and bottom hooks have, as part of the hook forging, overload indicator marks either side of the hook throat. By measuring the distance between the indicator marks, the hook can be quickly and easily checked to see if any stretch has occurred due to misuse or overloading.
- **HAND CHAIN JOINER:** a unique hand chain joiner is used as a quick and secure method of joining the hand chain without the need to cut, bend, open and close a link of existing hand chain.
- **FLEETING/CROSS HAULING:** the WH-C4 chain hoist is tested and certified for fleeting or cross hauling applications up to 45° from the vertical without deration. Ref. test document.
- **LOAD CHAIN:** WH-C4 chain blocks are fitted with load chain that fully complies with international standard BS EN818-7 Grade T (8).
- **TEMPERATURE RANGE:** -40°C to +120°C
- **OVERLOAD LIMITER:** available as an option upon request.
- The dual speed chain hoist can lift and lower the load chain 5 times faster than a regular chain hoist when it does not have a load.
- When the hoist is loaded, the lifting and lowering speed will be the same as a regular chain hoist.
- Equipped with Load Sensing Automatic Speed Transmission which is the first in this field.
- Smooth speed transmissions between high and standard speed without neutral position, which is reliable and safe.
- Equipped with an overload limiter ensuring safe operation.



Specifications

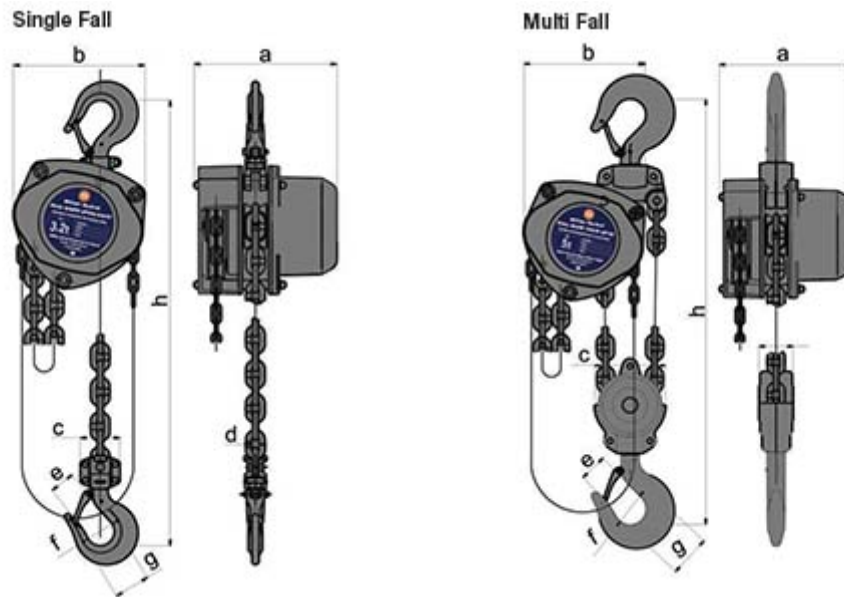

Part Code	WLL (t)	No. of Falls	Load Chain (mm)	Lift (m)	Mass (kg) 3m HOL	Extra Weight per m (kg)	Change from High Speed to Standard Speed (kg)	Change from Standard Speed to High Speed (kg)	Pulling Hand Chain to Lift 1m	
									High Speed (m)	Standard Speed (m)
023.DS.323	3.2	1	10 x 30	3	28.2	3.0	>55	<25	27	136
023.DS.503	5.0	2	10 x 30	3	42.4	5.2	>110	<50	54	272
023.DS.753	7.5	3	10 x 30	3	62.2	7.4	>165	<75	81	408
023.DS.1003	10.0	4	10 x 30	3	72.9	9.6	>165	<75	108	544
023.DS.1503	15.0	6	10 x 30	3	120.7	14.0	>275	<125	162	816
023.DS.2003	20.0	8	10 x 30	3	157.5	19.2	>330	<150	108 x 2	544 x 2
023.DS.3003	30.0	12	10 x 30	3	238.0	28.0	>330	<150	162 x 2	816 x 2
023.DS.5003	50.0	20	10 x 30	3	758.0	44.0	>330	<150	270 x 2	1360 x 2

Part Code	WLL (t)	a (mm)	b (mm)	c (mm)	d (mm)	e (mm)	f (mm)	g (mm)	h (mm)
023.DS.323	3.2	247	227	68.5	38.5	43	49.5	62	465
023.DS.503	5.0	247	275	133.0	64.0	51	60.0	79	600
023.DS.753	7.5	247	366	120.0	70.0	64	85.0	86	740
023.DS.1003	10.0	247	358	263.0	95.0	64	85.0	86	760
023.DS.1503	15.0	275	485	110.0	168.0	80	100.0	-	1000
023.DS.2003	20.0	285	648	286.0	123.0	82	110.0	-	1150
023.DS.3003	30.0	285	780	306.0	180.0	82	110.0	-	1500
023.DS.5003	50.0	585	832	480.0	310.0	133	170.0	-	1700