

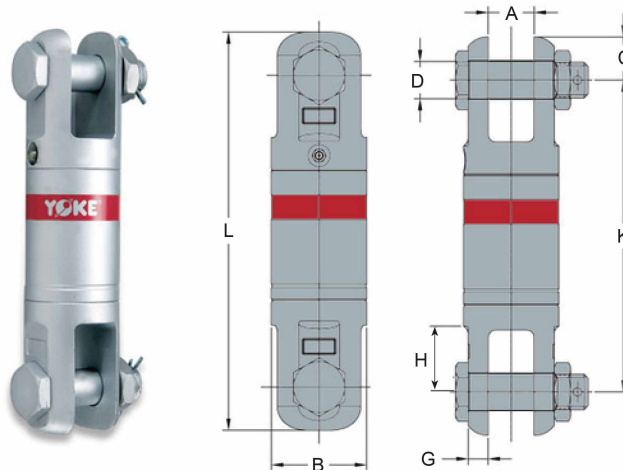

LIFTING EQUIPMENT STORE

## Yoke Jaw + Jaw Angular Swivel

- Yoke Angular Swivels are manufactured using the highest grade of material available.
- They are zinc plated for corrosion resistance and longer life. Angular Swivels are designed for low starting torque and high rotation speed, they are manufactured with grease fittings for superior performance.
- All Angular Swivels are 100% magnaflux crack detected. Designed with a safety factor 5:1



### SPECIFICATIONS - Metric

| Part Code  | Wire Line Size mm | WLL tonnes | A mm | B mm | C mm | D mm | G mm | H mm | K mm | L mm | Mass kg |
|------------|-------------------|------------|------|------|------|------|------|------|------|------|---------|
| 8-303-0075 | 6                 | 0.75       | 15   | 32   | 13   | 10   | 6    | 22   | 103  | 128  | 0.5     |
| 8-303-015  | 10                | 1.5        | 18   | 40   | 20   | 13   | 8    | 26   | 112  | 152  | 0.9     |
| 8-303-03   | 13                | 3.0        | 23   | 51   | 25   | 19   | 10   | 32   | 158  | 208  | 2.3     |
| 8-303-05   | 16                | 5.0        | 32   | 64   | 31   | 22   | 14   | 37   | 200  | 261  | 4.4     |
| 8-303-085  | 19                | 8.5        | 40   | 76   | 34   | 30   | 14   | 54   | 252  | 320  | 7.6     |
| 8-303-10   | 22                | 10.0       | 42   | 102  | 48   | 38   | 25   | 54   | 316  | 412  | 19.5    |
| 8-303-15   | 25                | 15.0       | 48   | 108  | 52   | 38   | 25   | 57   | 316  | 420  | 21.7    |
| 8-303-25   | 32                | 25.0       | 62   | 132  | 65   | 51   | 30   | 70   | 374  | 503  | 39.5    |

### SPECIFICATIONS - Imperial

| Part Code  | Wire Line Size inch | WLL tonnes | A inch | B inch | C inch | D inch | G inch | H inch | K inch | L inch | Mass lbs. |
|------------|---------------------|------------|--------|--------|--------|--------|--------|--------|--------|--------|-----------|
| 8-303-0075 | 1/4                 | 0.75       | 0.60   | 1.30   | 0.50   | 0.40   | 0.20   | 0.90   | 4.10   | 5.00   | 1.1       |
| 8-303-015  | 3/8                 | 1.5        | 0.70   | 1.60   | 0.80   | 0.50   | 0.30   | 1.00   | 4.40   | 6.00   | 2.0       |
| 8-303-03   | 1/2                 | 3.0        | 0.90   | 2.00   | 1.00   | 0.80   | 0.40   | 1.30   | 6.20   | 8.20   | 5.1       |
| 8-303-05   | 5/8                 | 5.0        | 1.30   | 2.50   | 1.20   | 0.90   | 0.60   | 1.50   | 8.00   | 10.30  | 9.7       |
| 8-303-085  | 3/4                 | 8.5        | 1.60   | 3.00   | 1.30   | 1.20   | 0.60   | 2.10   | 10.00  | 12.60  | 16.8      |
| 8-303-10   | 7/8                 | 10.0       | 1.70   | 4.00   | 1.90   | 1.50   | 1.00   | 2.10   | 12.40  | 16.20  | 43.0      |
| 8-303-15   | 1                   | 15.0       | 1.90   | 4.30   | 2.00   | 1.50   | 1.00   | 2.20   | 12.40  | 16.50  | 47.8      |
| 8-303-25   | 1-1/4               | 25.0       | 2.40   | 5.20   | 2.60   | 2.00   | 1.20   | 2.80   | 14.70  | 20.00  | 87.0      |