



William Hackett



DUAL SPEED CHAIN HOIST



5 x FASTER

e: liftingsales@williamhackett.co.uk
t: 01665 604200 f: 01665 604204

DUAL SPEED CHAIN HOIST - 5 times faster

- The dual speed chain hoist can lift and lower the load chain 5 times faster than a regular chain hoist when it does not have a load.
- Available capacity 3.2t to 50t.
- When the hoist is loaded, the lifting and lowering speed will be the same as a regular chain hoist.
- Equipped with Load Sensing Automatic Speed Transmission which is the first in this field.
- Smooth speed transmissions between high and standard speed without neutral position, which is reliable and safe.
- Equipped with an overload limiter ensuring safe operation.



Specification

Part Code	WLL tonnes	No. of Falls	Load Chain mm	Lift m	Mass kg	Extra Weight per m kg	Change from High Speed to Stand. Speed kg	Change from Stand. Speed to High Speed kg	Pulling Hand Chain to Lift 1m	
									High Speed m	Stand. Speed m
023.DS.323	3.2	1	10 x 30	3	31.0	3.0	> 55	< 25	27	136
023.DS.503	5.0	2	10 x 30	3	45.0	5.2	> 110	< 50	54	272
023.DS.753	7.5	3	10 x 30	3	63.0	7.4	> 165	< 75	81	408
023.DS.1003	10.0	4	10 x 30	3	81.0	9.6	> 165	< 75	108	544
023.DS.1503	15.0	6	10 x 30	3	130.0	14.0	> 275	< 125	162	816
023.DS.2003	20.0	8	10 x 30	3	174.0	19.2	> 330	< 150	108 x 2	544 x 2
023.DS.3003	30.0	12	10 x 30	3	301.0	28.0	> 330	< 150	162 x 2	816 x 2
023.DS.5003	50.0	20	10 x 30	3	465.0	44.0	> 330	< 150	270 x 2	1360 x 2

e: liftingsales@williamhackett.co.uk

t: +44 (0)1665 604200 f: +44 (0)1665 604204

DUAL SPEED CHAIN HOIST - 5 times faster

Specification

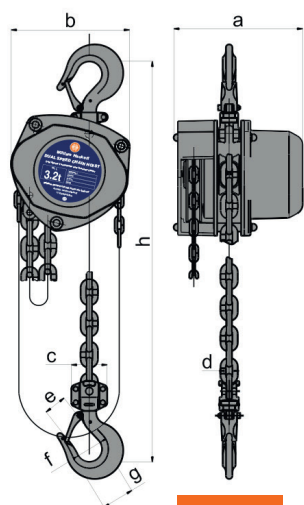

3.2t

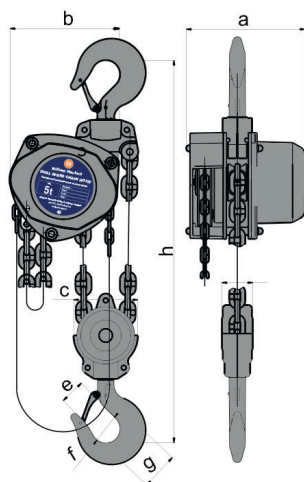

5t

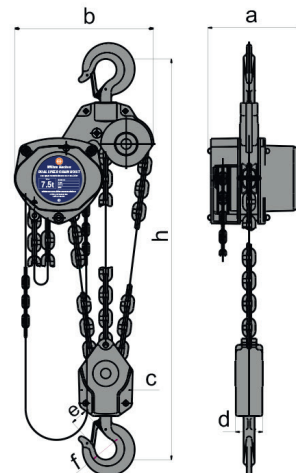

7.5t

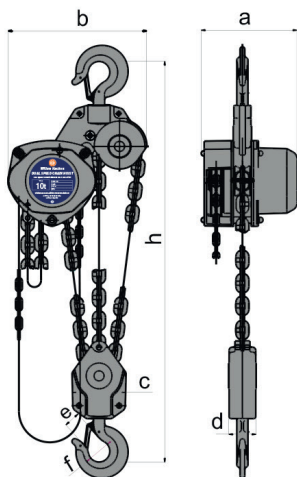

10t

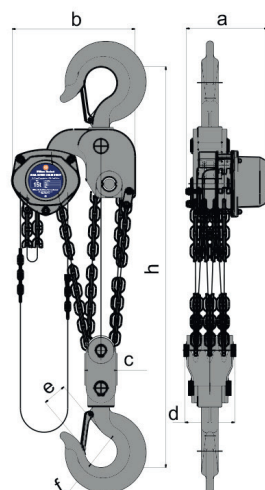

15t

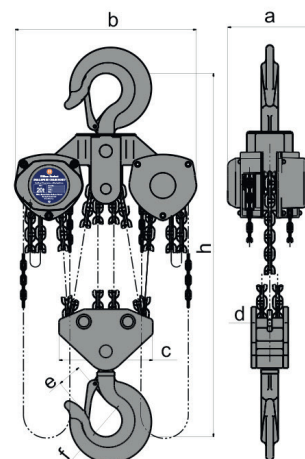

20t & 30t

Part Code	WLL t	a mm	b mm	c mm	d mm	e mm	f mm	g mm	h mm
023.DS.323	3.2	247	227	68.5	38.5	43	49.5	62	465
023.DS.503	5.0	247	275	133.0	64.0	51	60.0	79	600
023.DS.753	7.5	247	366	120.0	70.0	64	85.0	-	740
023.DS.1003	10.0	247	358	263.0	95.0	64	85.0	-	760
023.DS.1503	15.0	275	485	110.0	168.0	80	100.0	-	1000
023.DS.2003	20.0	285	648	286.0	123.0	82	110.0	-	1150
023.DS.3003	30.0	285	780	306.0	180.0	82	110.0	-	1500
023.DS.5003	50.0	585	832	480.0	310.0	133	170.0	-	1700

e: liftingsales@williamhackett.co.uk

t: +44 (0)1665 604200 f: +44 (0)1665 604204