

Instruction Manual

FM180



NOTE: Owner/Operator must read and understand this instruction manual before using the mover.

Contents

1. Application

2. Specifications

3. Assembly

4. Precautions and Preparation

5. Operation

6. Care and Maintenance

7. Parts Lists & Exploded Figures

THANK YOU VERY MUCH FOR CHOOSING OUR HYDRAULIC FURNITURE MOVER. FOR YOUR SAFETY AND CORRECT OPERATION, PLEASE CAREFULLY READ THE MANUAL BEFORE USE.

NOTE: All of the information reported herein is based on data available at the time of printing. The factory reserves the right to modify its own products at any time without notice or incurring in any sanction. Please verify with the factory for possible updates.

1. Application

The manual furniture mover has been developed for lifting and transporting cabinets and other large regular objects. For this reason, its supports are covered with foam rubber to prevent the goods being transported from damage.

Since the hydraulic furniture mover consists of two units, rectangular objects of varying length can be moved using a minimum of space. Due to the weight of the cabinet on the platform, it will hold itself in position when the units are standing vertically and the frame of the platform is in contact with its sides.

The securing strap, which has to be fastened correctly on both sides, is an additional absolute necessity.

The steering handles have a full lock of 180°, it means that goods can be transported in every direction. The platforms are raised by operating the lever of the pump; this lever must not be used for pulling or pushing the BIMOBIL. The platform is lowered by twisting the manual release valve of the compact hydraulic system anti-clockwise. Great care must be taken when lowering the platform, since the speed depends on the aperture of the valve as well as the weight of the goods to be transported. Before pumping up the system to raise the platforms the valve must be twisted clockwise and make sure it is closed.

If you operate properly, our hydraulic furniture mover will help you to move cabinets, furniture etc quickly and safely.

2. Specifications

Model	Capacity	Lifting Height	Lifting Plate Size	Net Weight
FM180A	1800kg	100mm	600×60mm	82kg
FM180B		250mm		86kg

3. Assembly

Remove the fork pin at the free end of the track rod, set the steering handles parallel to each other, and push the fork of the track rod over the arm of the steering handle. Then replace the previously- removed fork pin through the fork and arm and secure it with split ring.

The second unit is assembled in the same way.

4. Precautions and Preparation

4.1 The floor must be absolutely level, smooth and clean. There must be no inclines or slopes to be moved over. Make sure that the floor and the floor covering are to stand up to the loading imposed by the weight of the furniture being transported.

4.2 Check whether the cabinet or furniture to be transported contains any loose objects. These will have to be removed, or secured against slopping out of position.

4.3 Check whether the furniture is strong enough for the two opposite sides to take the weight of the piece via the transport units' platforms, and whether the upper supports of the transport units can hold the furniture to be transport without damaging it.

4.4 Find the weight of the furniture to be transported. The maximum load of 1800 kg/pair =900 kg for each unit must not be exceeded.

4.5 Find the center of gravity of the furniture to be transported. Along the furniture base, it is the decisive for the load that a single transport unit can bear, across the base, for the center of the transport unit, and, in connection with the height, for the moment of tilting that occurs when moving the furniture. When in use, the height of the center of gravity must not exceed 0.8m. The distance of the transport units to one another must not be less than 0.5m and no more than 4.0m (furniture of the securing straps).

4.6 Never use this equipment for towing by a vehicle.

5. Operation

Before using, the transport components should be checked for function, and for any damage. If there are visible defects, the components should not be used. Damaged parts must be replaced.

Since the hydraulic furniture mover consists of two parts, it is necessary for two persons to operate them.

Before transporting cabinets, the platforms should be lowered to the floor until the transport units are standing vertically.

Push the platform of the units under the side faces (narrow faces) of the cabinet until the top and bottom of the transport platform frame are resting against it. The centers of the platform must be beneath the center of gravity of the cabinet.

Place the securing straps in position and tighten them. The straps will connect both units and, when used correctly, prevent them from slipping out of their position. Here, the strap ends must be under direct tension, that is, the straps must not be pulling round the edge of a cabinet, etc. If necessary, an additional strap surrounding it must be employed. This must be fed through the strap loops on the units. However, the maximum overhang must not be more than 200 mm.

Pump up the platform about 1 cm, and carefully check whether the cabinet to be transported is standing stably on the platforms. Maybe

some adjustment should be done.

Both platforms must be raised at the same time and to the same amount. For the transport itself, the height off the floor must be a maximum of 2 cm only. When moving the cabinets, only push the transport units and choose the way to the cabinet's new position so that, if possible, it is only moved lengthwise. When moving cabinets sideways, always take the greatest care; there is a great risk of the cabinets tilting over.



The cabinet being transport must not be left unattended standing on the equipment; it must always be lowered onto the floor.

The securing straps may only be opened when the cabinet being transported, or the platforms, is standing on the floor.

Never use this equipment for towing by a vehicle.

6. Care and Maintenance

Our hydraulic furniture mover only requires little care and maintenance, but this must be carried out regularly. Depending on its use, the spindles and gear wheels must be re-greased weekly or monthly.

7. Parts Lists & Exploded Figures

7.1 For Lifting Height of 100mm (FM180A)

Item No.	Description	Qty
01	Dust-proof Cover	4
02	Cushion	2
03	Lock nut M10	2
04	Woven Stripe	1
05	Screw M10×70	2
06A	Lifting Frame	1
07	Cargo Lashings	1
08A	Supporting Frame	1
09	Nylon Washer	2
10	Cylindrical Spring Pin $\Phi 6 \times 30$	2
11	Handle Assy.	2
12	Hand Tube	1
13	Split Ring 9	2
14A	Hydraulic Jack	1
15	Screw M6×20	2
16A	Screw M6×12	1
17A	Lock nut M6	2
18	Dust-proof Ring	2
19	Bearing 8204	2
20A	Supporting Rod	2
21	Screw M12×85	2
22	Washer 12	2
23	Spring washer	2
24	Nut M12	2
25	Bushing	4
26	Bushing	2

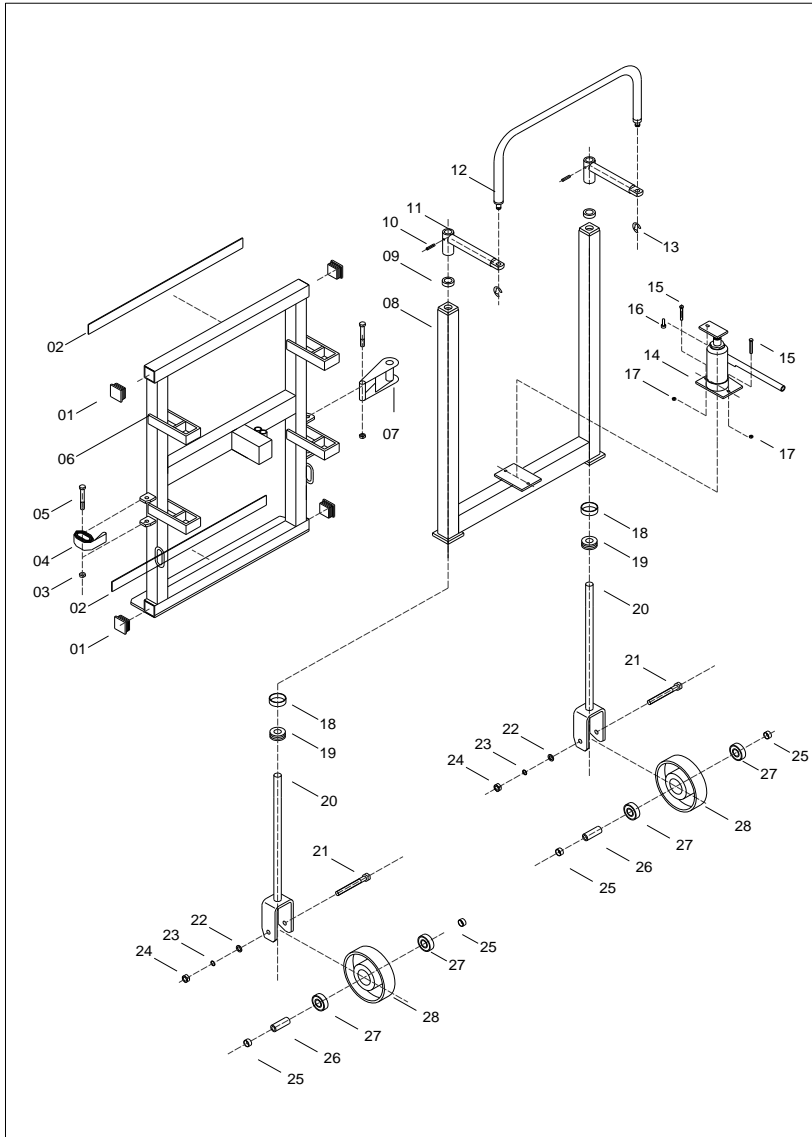

7.2 For Lifting Height of 250mm(FM180B)

Item No.	Description	Qty
01	Dust-proof Cover	4
02	Cushion	2
03	Lock nut M10	2
04	Woven Stripe	1
05	Screw M10×70	2
06B	Lifting Frame	1
07	Cargo Lashings	1
08B	Supporting Frame	1
09	Nylon Washer	2
10	Cylindrical Spring Pin $\Phi 6 \times 30$	2
11	Handle Assy.	2
12	Hand Tube	1
13	Split Ring 9	2
14B	Hydraulic Jack	1
15	Screw M6×20	2
16B	Split Ring 8	2
17B	Pin	1
18	Dust-proof Ring	2
19	Bearing 8204	2
20B	Supporting Rod	2
21	Screw M12×85	2
22	Washer 12	2
23	Spring washer 12	2
24	Nut M12	2
25	Bushing	4
26	Bushing	2
27	Bearing	2

